

SECTION I XE
1300 MHz COUNTER
5305B

OPERATING AND SERVICE MANUAL

SERIAL PREFIX: 1616A

This section applies directly to Model 5305B 1300 MHz Counters having Serial Prefix 1616A. This section is provided in loose-leaf form for incorporation into the 5300 Measurement System Manual. 5305A instruments are documented in a separate manual.

NEWER INSTRUMENTS

This section with enclosed "Manual Changes" sheet applies directly to HP Model 5305B 1300 MHz Counters having Serial Prefix numbers above 1616A.

OLDER INSTRUMENTS

Subsection VII of this document contains information pertinent to all older instruments.

Copyright HEWLETT-PACKARD COMPANY 1976
5301 STEVENS CREEK BLVD., SANTA CLARA, CALIF. 95050

Printed: AUG 1976

MANUAL PART NO. 05305-90008
MICROFICHE PART NO. 05305-90009

PRINTED IN U.S.A.

TABLE OF CONTENTS

Section		Page
I XE	5305B 1300 MHz Counter	
Subsection		
I	GENERAL INFORMATION	9E-1-1
	9E-1-1. Scope of Manual	9E-1-1
	9E-1-3. Description	9E-1-1
	9E-1-6. Instrument Identification	9E-1-2
	9E-1-8. Equipment Supplied	9E-1-2
	9E-1-10. Accessories Available	9E-1-2
	9E-1-12. 5300A/5300B Compatibility	9E-1-2
	9E-1-14. Specifications	9E-1-2
	9E-1-16. Recommended Test Equipment	9E-1-2
II	INSTALLATION	9E-2-1
	9E-2-1. Unpacking and Inspection	9E-2-1
	9E-2-3. Storage and Shipment	9E-2-1
	9E-2-6. Installation and Removal of Plug-On	9E-2-1
	9E-2-8. Portable Operation	9E-2-1
III	OPERATION	9E-3-1
	9E-3-1. Introduction	9E-3-1
	9E-3-3. Operating Characteristics	9E-3-1
	9E-3-5. Input Channels	9E-3-1
	9E-3-9. Resolution	9E-3-1
	9E-3-11. 1300 MHz Channel Input Levels	9E-3-2
IV	THEORY OF OPERATION	9E-4-1
	9E-4-1. Introduction	9E-4-1
	9E-4-3. A1 Logic Board	9E-4-1
	9E-4-5. High Impedance Amplifier	9E-4-1
	9E-4-12. Counting Circuits	9E-4-1
	9E-4-16. Frequency Multiplier	9E-4-2
	9E-4-30. 1300 MHz \times Circuit	9E-4-4
	9E-4-32. A2 1300 MHz Amplifier Assembly	9E-4-4
V	MAINTENANCE	9E-5-1
	9E-5-1. Introduction	9E-5-1
	9E-5-3. Recommended Test Equipment	9E-5-1
	9E-5-5. In-Cabinet Performance Check	9E-5-1
	9E-5-7. Instrument Access	9E-5-1
	9E-5-9. Periodic Maintenance	9E-5-1
	9E-5-11. Maintenance and Repair	9E-5-1
	9E-5-15. Adjustments	9E-5-5
	9E-5-17. Channel A Adjustments	9E-5-5
	9E-5-19. Channel B Adjustments	9E-5-6
	9E-5-21. Troubleshooting	9E-5-6
	9E-5-25. 100 MHz Channel Troubleshooting	9E-5-6
	9E-5-27. 1300 MHz Channel Troubleshooting	9E-5-7
	9E-5-29. Both Channels Inoperative	9E-5-7
	9E-5-34. Frequency Multiplier	9E-5-7
VI	REPLACEABLE PARTS	9E-6-1
	9E-6-1. Introduction	9E-6-1
	9E-6-3. Ordering Information	9E-6-1

TABLE OF CONTENTS (Cont'd)

Subsection		Page
VII	MANUAL CHANGES	9E-7-1
	9E-7-1. Manual Changes	9E-7-1
	9E-7-3. Newer Instruments	9E-7-1
VIII	CIRCUIT DIAGRAMS	9E-8-1
	9E-8-1. Introduction	9E-8-1

LIST OF TABLES

Table		Page
9E-1-1.	Specifications	9E-1-3
9E-1-2.	Recommended Test Equipment	9E-1-4
9E-3-1.	Resolution vs Gate Time	9E-3-1
9E-5-1.	In-Cabinet Performance Check	9E-5-3
9E-5-2.	Erroneous Displays Caused by U4	9E-5-7
9E-6-1.	Replaceable Parts	9E-6-3
9E-6-2.	Manufacturers Code List	9E-6-8
9E-8-1.	Counter Signal List	9E-8-1

LIST OF FIGURES

Figure		Page
9E-3-1.	dBm-to-Voltage Conversions	9E-3-1
9E-3-2.	Front Panel Controls, Connectors, and Indicators	9E-3-2
9E-3-3.	Self-Check Measurements	9E-3-3
9E-3-4.	100 MHz Channel Frequency Measurements	9E-3-4
9E-3-5.	90 MHz-1300 MHz Channel Frequency Measurements	9E-3-5
9E-4-1.	Phase Detector Block Diagram	9E-4-2
9E-4-2.	VCO Waveforms at about 2 MHz	9E-4-3
9E-4-3.	VCO Characteristics	9E-4-4
9E-5-1.	Separation Procedure	9E-5-2
9E-5-2.	Test Setup for 1300 MHz Adjustment	9E-5-5
9E-6-1.	Details of Input Connector J1 and Fuse Mounting	9E-6-8
9E-8-1.	Channel B and Frequency Multiplier Circuits, Schematic Diagram	9E-8-5
9E-8-2.	Channel A and Logic Board Circuits, Schematic Diagram	9E-8-9

SECTION I XE 5305B 1300 MHz COUNTER

SUBSECTION I GENERAL INFORMATION

9E-1-1. SCOPE OF MANUAL

9E-1-2. This manual provides operating and service information for the Hewlett-Packard Model 5305B 1300 MHz Counter. Information for the mainframes (5300A or 5300B) is contained in separate manuals. This manual is divided into eight sections containing the following information:

SECTION I GENERAL INFORMATION covers a description of the counter, equipment supplied, accessories, specifications, and recommended test equipment.

SECTION II INSTALLATION provides instructions for unpacking, inspection, preparation for use, shipment, and storage for the counter.

SECTION III OPERATION covers the counter's operating features including front-panel controls, input level considerations, and operating and self-check procedures.

SECTION IV THEORY OF OPERATION describes the counter's theory of operation.

SECTION V MAINTENANCE contains an in-cabinet performance check, adjustments, and troubleshooting information.

SECTION VI REPLACEABLE PARTS provides a complete list of the counter's replaceable parts and information for ordering parts.

SECTION VII MANUAL CHANGES provides information necessary to backdate the manual to cover earlier instruments.

SECTION VIII SCHEMATIC DIAGRAMS THEORY contains schematic diagrams, and component locators.

9E-1-3. DESCRIPTION

9E-1-4. The 5305B extends the frequency measuring capability of the 5300 Measuring System to the UHF range. The counter features burst or CW measurements to 1300 MHz, separate channels to cover 90 MHz-1300 MHz and 50 Hz to 100 MHz both with 20 mV rms sensitivity, high resolution mode for fast tone measurements, automatic gain control for both channels or manual attenuator control for the high frequency channel, fuse protected high frequency channel, and probe power plus accessory preamp for high-sensitivity applications. When operating in the high resolution mode, a phase-locked multiplier gives 1000 times improvement in the resolution of audio tone measurements. This feature is especially useful for servicing equipment using tone

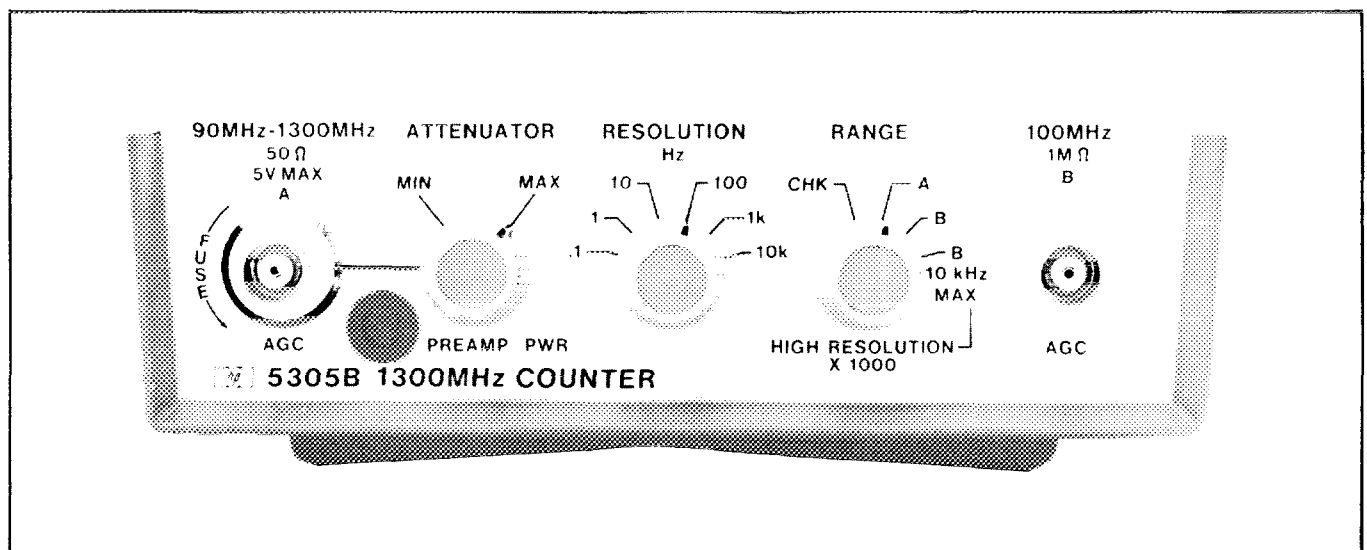

modulation for digital encoding on the carrier. The 5305B is applicable to mobile communication bands in addition to VHF and UHF TV transmissions plus TACAN/DME and ATC radar transponders.

9E-1-5. The 10855A Preamplifier is available to boost the UHF sensitivity of the counter by a minimum of 22 dB.

9E-1-6. INSTRUMENT IDENTIFICATION

9E-1-7. Hewlett-Packard instruments have a 2-section, 10-character serial number (0000A00000) which is located on the rear panel. The 4-digit serial prefix identifies instrument changes. If the serial prefix of your instrument differs from that listed on the title page of this manual, there are differences between this manual and your instrument. Instruments having higher serial prefixes are covered with a "Manual Changes" sheet included with this manual. If the change sheet is missing, contact the nearest Hewlett-Packard Sales and Service Office listed at the back of this manual. Instruments having a lower serial prefix than that listed on the title page, are covered in the backdating Section VII.

9E-1-8. EQUIPMENT SUPPLIED

9E-1-9. The 5305B is supplied with an operating and service manual.

9E-1-10. ACCESSORIES AVAILABLE

9E-1-11. For high-sensitivity UHF applications, the 10855A Preamplifier can be used with the 5305B. The 10855A covers the 2 MHz to 1.3 GHz range with a gain of 22 dB minimum. Power requirements are +15 volts at ± 40 mA. The 5305B has a front-panel connector to supply the required +15 volts to 10855A.

9E-1-12. 5300A/5300B COMPATIBILITY

9E-1-13. The 5305B is fully compatible with either the 5300A or the 5300B mainframe. Unlike the 5305A, a high-stability time base is not available for the 5305B, however a high-stability time base is available for the 5300B.

9E-1-14. SPECIFICATIONS

9E-1-15. Specifications for the 5305B are listed in Table 9E-1-1.

9E-1-16. RECOMMENDED TEST EQUIPMENT

9E-1-17. Test equipment recommended for testing, calibration, and repair of the 5305B is listed in Table 1-2.

Table 9E-1-1. Specifications

INPUT CHANNEL A (CW OR BURST)

Range: 90 MHz to 1300 MHz, prescaled by 16

Sensitivity: 20 mV rms

Impedance: 50 Ω

Attenuator: Continuously variable to give optimum noise suppression for signals up to 3.5V rms.

Overload Protection: 5V rms, maximum. Input circuitry is fuse protected; fuse is located in BNC connector and is accessible from the front panel.

Operating Dynamic Range: >47 dB

INPUT CHANNEL B (NORMAL AND HIGH RESOLUTION MODE)

Range: 50 Hz to 100 MHz, direct count in normal mode. 50 Hz to 10 kHz in high resolution mode. In the high resolution mode, the 5305B uses a phase-locked multiplier to increase resolution X1000 over normal measurement resolution.

Sensitivity: 20 mV rms

Impedance: 1 M Ω shunted by less than 40 pF.

Overload Protection: 250V rms from 50 Hz to 10 kHz, declining to 10V rms above 10 MHz.

Search Indicator: In high-resolution mode the "S" annunciator is lit whenever the input is beyond the proper frequency range, or too weak to measure, or during the brief acquisition time following signal interruption.

Automatic Hold: In high-resolution mode, the last valid reading is held in display when input is terminated.

FREQUENCY MEASUREMENT

RESOLUTION (SELECTABLE):

Normal Mode (50 Hz to 1300 MHz): 0.1 Hz to 10000 Hz in decade steps corresponding to gate times of 10 sec to 0.0001 sec in decade steps on channel B and to gate times of 160 sec to .0016 sec in decade steps on channel A.

High Resolution Mode (50 Hz to 10 kHz): 0.0001, 0.001, 0.01, 0.1, 1, 10 Hz corresponding to 10, 1, 0.1, 0.01, 0.001, 0.0001 second gate times on channel B.

Accuracy: ± 1 digit displayed \pm time base accuracy.

Display: Hz, kHz, MHz with positioned decimal point.

GENERAL

Check: Counts internal 10 MHz reference frequency to check counting circuits.

Operating Temperature: 0 $^{\circ}$ to 50 $^{\circ}$ C.

Power Requirements: Nominally 12 watts including mainframe.

Weight: Net 1.0 kg (2-1/4 lbs.); Shipping 1.8 kg (4 lbs.)

Dimensions: With mainframe, 89 mm H (3-1/2") x 160 mm W (6-1/4") x 248 mm L (9-3/4").

Compatible Mainframes: 5300A (6 digits) or 5300B (8 digits). 5300B is recommended.

Accessories: 10855A Preamp (22 dB gain).

Table 9E-1-2. Recommended Test Equipment

Instrument	Required Characteristics	Recommended Type
Oscilloscope	50 MHz Bandwidth	HP 180A
Vertical Plug-In	50 mV/div Sensitivity	HP 1801A
Time Base Plug-In	50 MHz Bandwidth	HP 1821A
Sampling Plug-In	1000 MHz	HP 1810A
Optical Sampling Plug-In	If desired to measure up to 1300 MHz	HP 1811A/1432A
Synthesized Signal Generator	1300 MHz	HP 8660B/86602A
Power Meter	-30 dBm to +10 dBm	HP 435A
Power Sensor	90 MHz to 1300 MHz	HP 8481A
Test Oscillator	50 Hz to 10 MHz 3V rms	HP 651B
Mainframe		HP 5300B
Digital Voltmeter	-5V to +20 Vdc	HP 5306A
Power Splitter	50 ohms 90 MHz to 1300 MHz	HP 11667A
Scope Probe	10:1 1 Meg Ω	HP 10004D

SECTION IX E 5305B 1300 MHz COUNTER

SUBSECTION II INSTALLATION

9E-2-1. UNPACKING AND INSPECTION

9E-2-2. If the shipping carton is damaged, ask that the carrier's agent be present when the instrument is unpacked. Inspect the instruments for damage, such as scratches, dents, broken knobs, etc. If the instrument is damaged or fails to meet performance tests when used with the 5300B Measuring System, notify the carrier and the nearest Hewlett-Packard Sales and Service Office immediately. Performance check procedures are located in Section IX E-5, and Sales and Service Offices are listed in Section VI of the 5300B portion of the manual. Retain the shipping carton and the padding material for the carrier's inspection. The Sales and Service Office will arrange for the repair or replacement of the instrument without waiting for the claim against the carrier to be settled.

9E-2-3. STORAGE AND SHIPMENT

9E-2-4. PACKAGING. To protect valuable electronic equipment during storage and shipment, always use the best packaging methods available. Your Hewlett-Packard Sales and Service Office can provide packaging material, such as that used for original factory packaging. Contract packaging companies in many cities can provide dependable custom packaging on short notice. Here is one recommended packaging method:

a. The original container is a corrugated cardboard box with 200 lbs. burst test (HP Part No. 9211-1620). The instrument is secured and protected, while in the box, by a top and bottom molded frame of poly-

styrene foam (HP No. 9220-1545). Also included with the instrument is a plastic dust-protection cover HP Part No. 9220-1762.

9E-2-5. ENVIRONMENT. Conditions during storage and shipment should be normally limited as follows:

- Maximum altitude: 25,000 ft.
- Minimum temperature: $-40^{\circ}\text{F}(-40^{\circ}\text{C})$.
- Maximum temperature: $+167^{\circ}\text{F}(+75^{\circ}\text{C})$.

9E-2-6. INSTALLATION AND REMOVAL OF PLUG-ON

9E-2-7. The 5305B 1300 MHz Counter must be used with a mating 5300A or B Measuring System, before any measurements can be made. To mate the 5305B 1300 MHz Counter with a 5300 Measuring System, see Figure 2-1 and Paragraph 2-11 in the 5300 portion of the manual.

9E-2-8. PORTABLE OPERATION

9E-2-9. The use of the HP Model 5310A Battery Pack enables the 5300 Measuring System and 5305B 1300 MHz Counter to be used in areas removed from ac power sources. The 5310A Battery Pack typically provides 5 hours of portable operating time before recharging. Tables 1-2 and 1-4 in 5300 portion of the manual lists the HP 5310A Battery Pack as an available accessory. Documentation on the 5310A is also included in Section IV through VIII of the 5300 portion of the manual. To prepare the 5300/5305B for portable operation, refer to Paragraph 2-13 and Figure 2-2 in the 5300 portion of the manual.

SECTION I XE

5305B 1300 MHz COUNTER

SUBSECTION III

OPERATION

9E-3-1. INTRODUCTION

9E-3-2. This section covers operating information for the 5305B including a description of controls, indicators, and connectors, resolution, input levels, and operating procedures for frequency measurements and self check.

9E-3-3. OPERATING CHARACTERISTICS

9E-3-4. The 5305B Counter performs frequency measurements by means of two separate input channels. These channels provide a combination of low-frequency measurements and high-sensitivity, high-frequency measurements. Measurement capability is applicable to all frequencies in the VHF and mobile communication bands in addition to a significant portion of the UHF band. The 10855A Preamplifier can be used to boost the UHF input sensitivity by 22 dB.

9E-3-5. Input Channels

9E-3-6. Two input channels are provided, Channel A - 90 MHz to 1300 MHz and Channel B - 50 Hz to 100 MHz. Both channels have 20 mV rms sensitivity.

9E-3-7. Channel A prescales the input frequency by 16 and can be used to measure CW or burst signals. Input coupling is ac. An AGC circuit is included to give a dynamic range of >47 dB. An internal fuse, located inside the input jack, protects circuitry from overloads greater than 5V rms. Note that a blown fuse may not prevent the counter from measuring high-frequency inputs. In this instance, the counter's circuitry is no longer protected, i.e., as it would be at lower frequencies by a good open circuit. If the fuse blows, a replacement fuse is supplied with the instrument.

9E-3-8. The frequency range of Channel B depends on the mode of operation - normal or high resolution. In the normal mode, Channel B covers 50 Hz to 100 MHz. With high-resolution selected, Channel B covers 50 Hz to 10 kHz. The high resolution mode uses a phase-locked multiplier to increase resolution by a factor of 1000. Input impedance is 1 Megohm shunted by less than 40 pF. A 10 to 1 divider probe can be used to increase the input impedance to 10 Megohms.

9E-3-9. RESOLUTION

9E-3-10. The 5305B has a RESOLUTION switch which determines the least-significant digit (LSD) displayed. For example, with an input of 123,456 Hz, setting the RESOLUTION switch to 1 kHz places the "3" in the LSD. Setting the switch to 10 Hz, places the "5" in the LSD. Resolution can be expressed in terms of the counter's gate time, as shown in Table 9E-3-1.

Table 9E-3-1. Resolution vs Gate time

RESOLUTION	GATE TIME	
	80 MHz	1100 MHz
.1 Hz	10 s	160 s
1 Hz	1 s	16 s
10 Hz	.1 s	1.6 s
100 Hz	.01 s	.16 s
1 kHz	1 ms	16 ms
10 kHz	.1 ms	1.6 ms

Figure 9E-3-1. dBm-to-Voltage Conversions

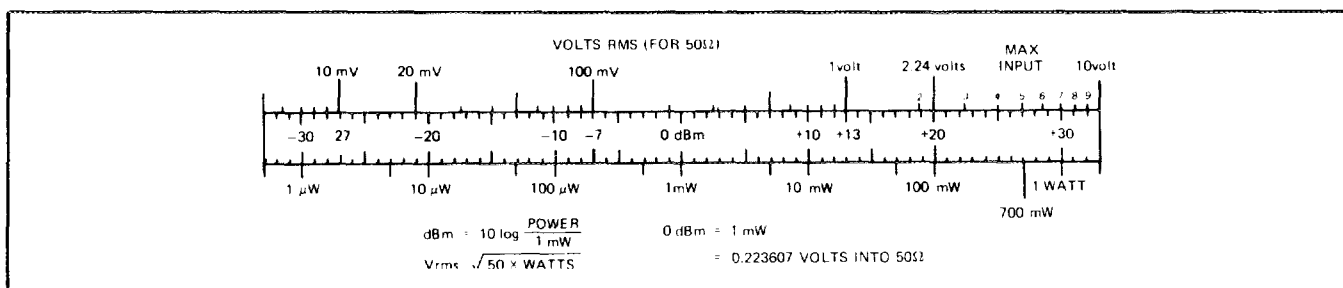

9E-3-11. 1300 MHz Channel Input Levels

9E-3-12. The 1300 MHz channel is a 50-ohm system with a maximum input of 5V rms. Figure 9E-3-1 provides a conversion scale for determining respective

levels of voltage, power, and dBm. This scale applies to a 50-ohm system and is not applicable to the 100 MHz channel. The shaded area represents the specified operating range of the 1300 MHz channel.

Figure 9E-3-2. Front Panel Controls, Connectors, and Indicators

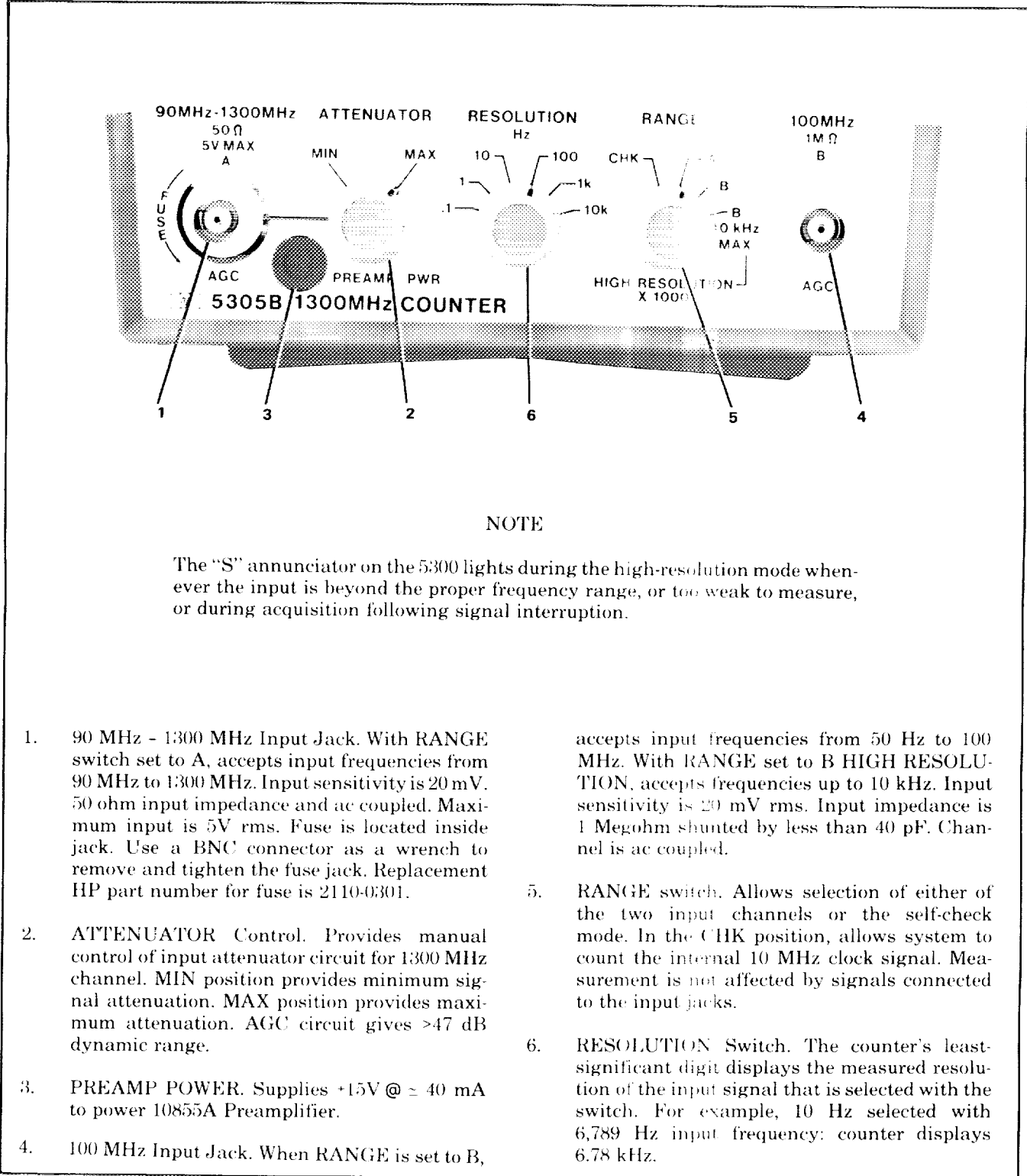
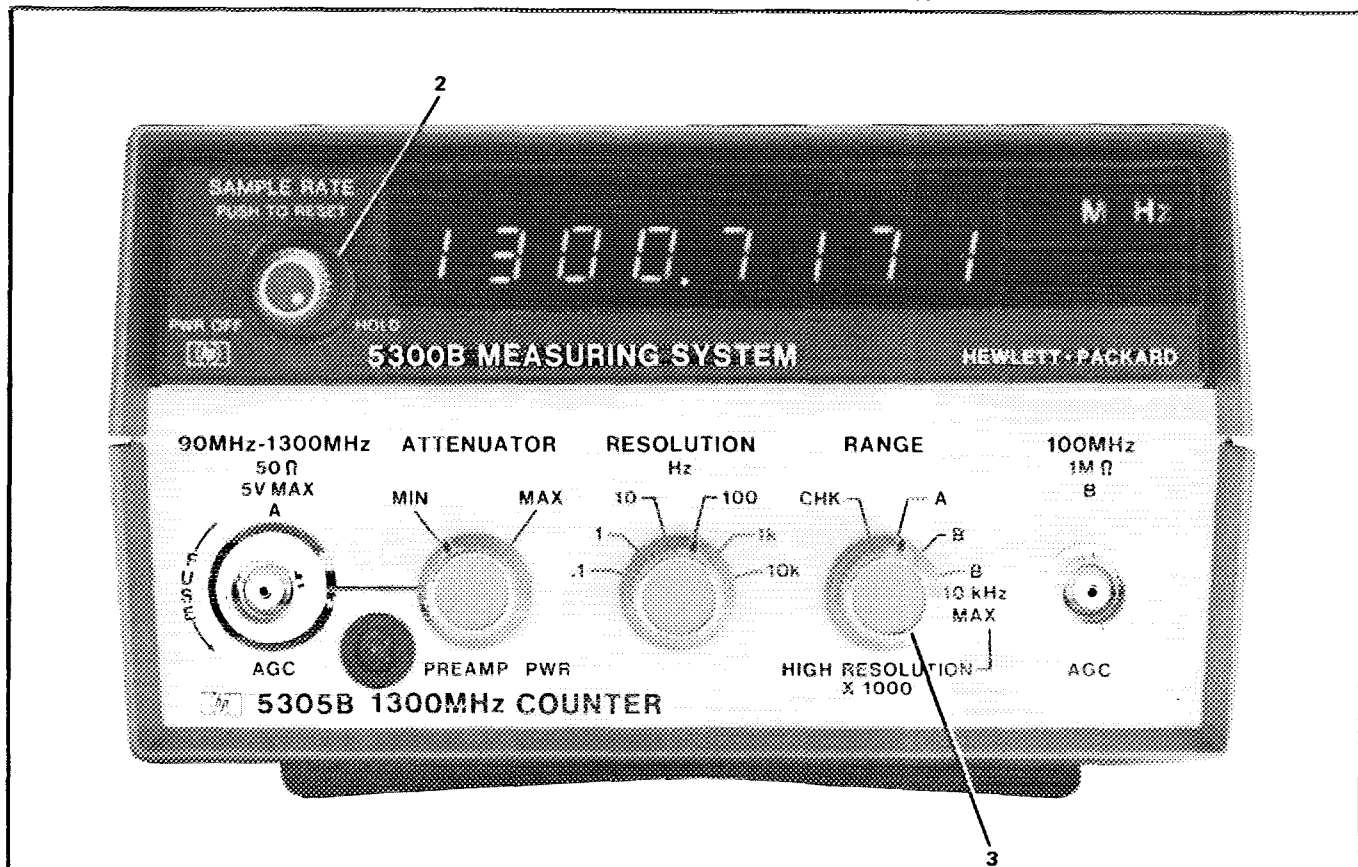

Figure 9E-3-3. Self-Check Measurements



1. Apply input power to 5300 ac receptacle.
2. Turn counter on with 5300 SAMPLE RATE control. Adjust SAMPLE RATE for minimum display time (full ccw).
3. Set RANGE switch to CHK position. Display is a function of RESOLUTION switch.

Resolution Selector	5300A Self Check		5300B Self Check	
	Display	Annunciator	Display	Annunciator
10 kHz	0010.00	M, Hz	000010.00±1	M, Hz
1 kHz	010.000	M, Hz	00010.000±1	M, Hz
100 Hz	10.0000	M, Hz, C	0010.0000±1	M, Hz, C
10 Hz	0.00000	M, Hz, C	010.00000±1	M, Hz, C
1 Hz	•000.000	K, Hz, C	10000.000±1	K, Hz, C
.1 Hz	•00.0000	K, Hz, C	0000.0000±1	K, Hz, C

•Indicates overflow light is on.

Figure 9E-3-4. 100 MHz Channel Frequency Measurements

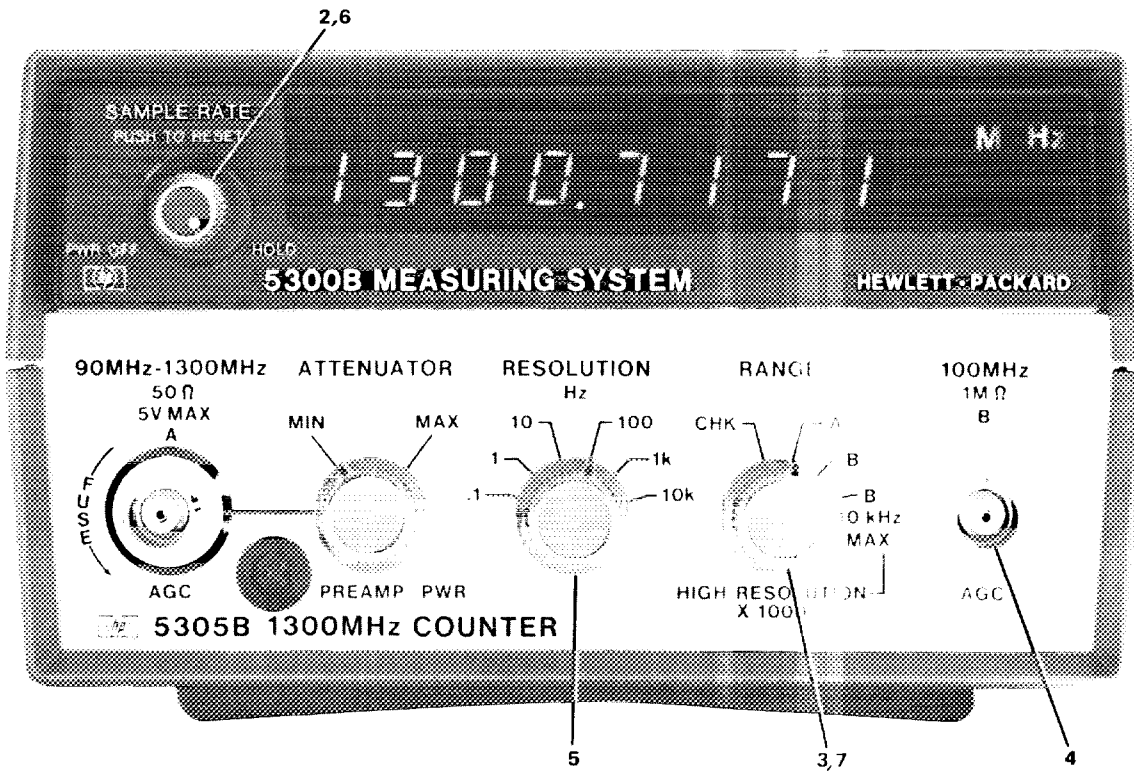

1. Apply power to 5300 ac receptacle.
2. Turn counter on with 5300 SAMPLE RATE control.
3. Set RANGE switch to B position.
4. Connect input signal to 100 MHz jack.
5. Set RESOLUTION switch for number of digits desired in display.
6. Adjust SAMPLE RATE control for convenient interval between measurements.
7. For high resolution, set RANGE switch to B 10 kHz MAX - HIGH RESOLUTION X1000. This limits the input frequency to 10 kHz but gives resolution up to 4 decimal places.

Figure 9E-3-5. 90 MHz - 1300 MHz Channel Frequency Measurements

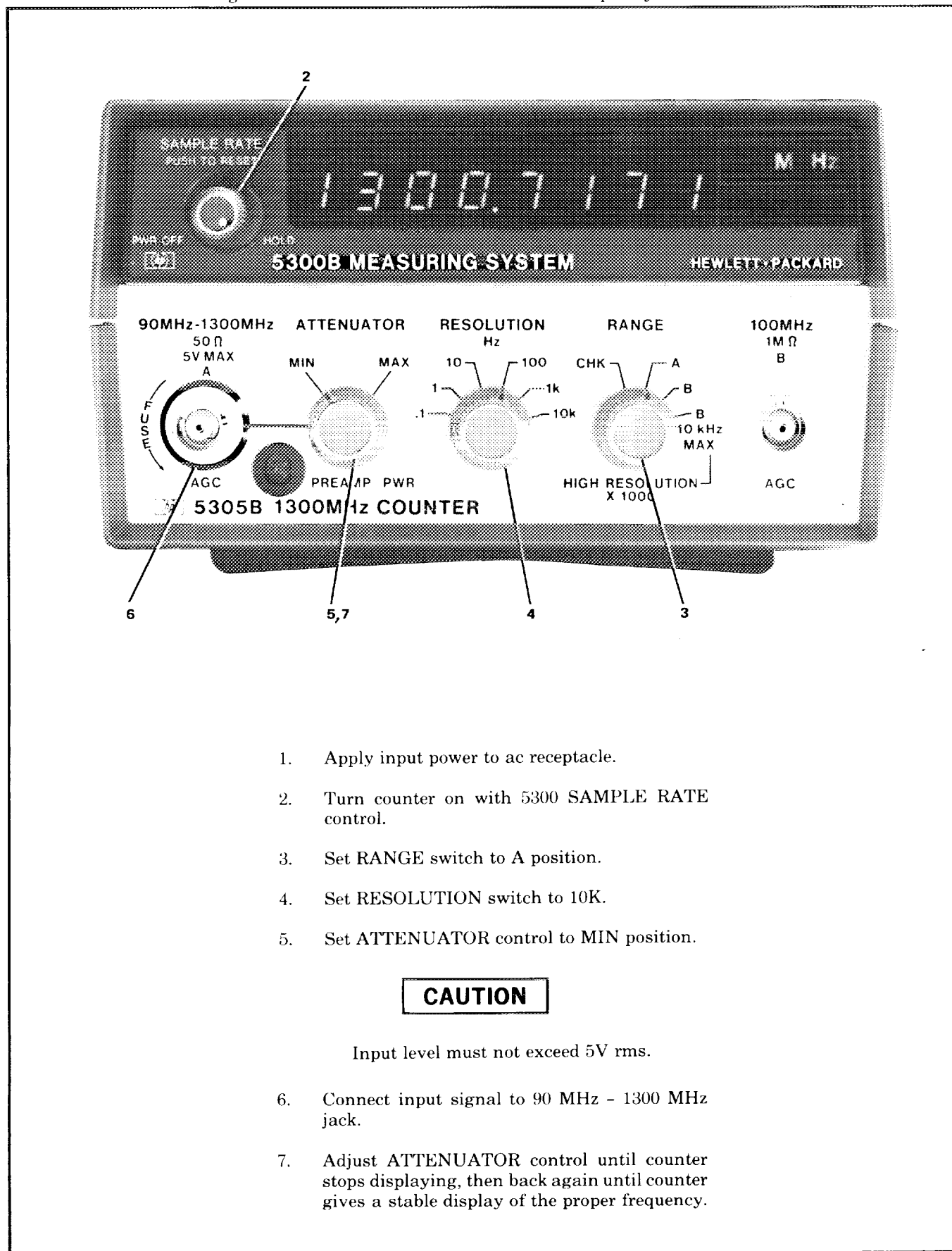

1. Apply input power to ac receptacle.
2. Turn counter on with 5300 SAMPLE RATE control.
3. Set RANGE switch to A position.
4. Set RESOLUTION switch to 10K.
5. Set ATTENUATOR control to MIN position.

CAUTION

Input level must not exceed 5V rms.

6. Connect input signal to 90 MHz - 1300 MHz jack.
7. Adjust ATTENUATOR control until counter stops displaying, then back again until counter gives a stable display of the proper frequency.

SECTION IX E 5305B 1300 MHz COUNTER

SUBSECTION IV THEORY OF OPERATION

9E-4-1. INTRODUCTION

9E-4-2. The 5305B consists of two assemblies, Logic Board A1 and 1300 MHz amplifier A2. Two input channels for frequency measurements are provided, Channel A accepts signals from 90 MHz to 1300 MHz and Channel B is used for signal inputs up to 100 MHz. Channel B signals are connected directly to the A1 Logic Board. Channel A signal inputs are routed to the 1300 MHz Amplifier A2. The following theory describes the two assemblies.

9E-4-3. A1 LOGIC BOARD

9E-4-4. A1 consists of the following major circuits; High-Impedance Amplifier, Counting, Frequency Multiplier, and 1300 MHz. Paragraphs 9E-4-5 through 9E-4-30 describe the theory of operation for these circuits.

9E-4-5. High Impedance Amplifier

9E-4-6. The high-impedance amplifier consists of three main stages: (1) An input buffer (Q1, Q2) that provides high input impedance at unity gain. (2) An AGC (automatic gain control) amplifier (U6B and C) to generate the required gain to maintain a relatively constant output with a wide range of inputs. This assures that the counter will read the proper frequency in the presence of noisy input signals. (3) A Schmitt-trigger U6A and driver U16 to convert noisy, slow-changing signals to "clean" square waves with fast rise times to drive the counting circuits.

9E-4-7. INPUT CIRCUIT OPERATION. The signal enters the amplifier through dc blocking capacitor C4, which, along with C7, R10, R7, CR4, and CR2, protects against large ac peaks at low frequencies. At high frequencies, R7 and CR4 and CR2 provide the input protection for the unity-gain boot-strapped source-follower circuit Q1 and Q2.

9E-4-8. AGC OPERATION. For small signal levels (below ≈ 10 mV rms), the output of U8 pin 1 is $< .6V$ (with no input signal, the voltage is about $-3.5V$). This causes Q5 and Q4 to turn off which results in Q3 turn-

ing on. The low source-to-drain impedance (50Ω) shunts resistor R12. The signal passes unattenuated through Q3 to amplifier U6C. The output at U6B(6) feeds the signal through R33 and C25. The signal is converted to dc by CR9, C24 and R35. As the input signal level increases, the AGC voltage at U8(1) increases above .6 volts to a maximum of $\approx +2$ volts. Both CR5 and CR7 begin to conduct and their resistance drops rapidly to a few ohms, shunting most of the signal to ground. At the same time, Q5 begins to conduct and causes Q4 to conduct.

9E-4-9. When Q4 is full on, it generates more than -5 volts gate-to-source voltage on Q3. This tends to "pinch off" Q3, thereby raising its resistance. With R6 as the main signal path, only a small portion (10 to 20 mV p-p) of a large input signal (10V p-p) drives amplifier U6C. This prevents saturation of U6, and prevents the degradation in signal-to-noise ratio that saturation would cause. Thus Schmitt trigger U6A is triggered only by the largest signal at the input and not noise.

9E-4-10. DC FEEDBACK AND DUTY CYCLE CONTROL. The first two amplifier stages of U6 have a fixed voltage gain of typically 30 to 40 with a bandwidth of 100 MHz. U8 monitors the output of U6B and regulates the dc level at about 1.3V, regardless of temperature and device differences.

9E-4-11. SCHMITT TRIGGER AND OUTPUT. The third stage of U6 is used as a Schmitt trigger. This circuit shapes the .6V p-p sine wave at its input into a .8V p-p square wave. It will respond to signals less than 0.3V p-p in amplitude and thus rejects noise on the input signal. U16 amplifies the square wave and converts it to TTL levels to drive U22.

9E-4-12. Counting Circuits

9E-4-13. The following paragraphs describe the counting circuits that are common to all input modes. The RANGE switch enables one of four NOR gates to pass its respective signal to the Main Gate U13A and to the arm flip-flop, U17B. The signals are (1) Channel A divided by 16, U12C; (2) Channel B, U12A; (3) Channel B times 1000(PLO), U12B; and (4) 10 MHz clock (check), U13B.

9E-4-14. In the Channel B mode, for example, the operation is as follows. Once the sample rate runs down and the INHIBIT line returns high, the next signal pulse from U12A sets U17B. The High output from U16D(13) arms the counter by allowing the CLOSE line to go High. The arm signal also passes the 10 MHz clock signal to the mainframe through U10A and U10B. The mainframe responds by clocking U17A with a LOG 0 pulse, which sets the Q output Low and opens the Main Gate. The signal now passes to the decade counter, U14, where it is divided by 10. The data output of U14 feeds U13C, which provides a 60/40 duty cycle of the divided signal to level translators Q9 and Q10. The signal then enters the main frame's counting assembly on the F1 line.

NOTE

U6, 12, 13, 14, 17, and 25 are ECL devices that are connected to the +5V supply. They set the logic states to $\approx 4.3V$ for a High and $\approx 3.2V$ for a Low.

9E-4-15. The measurement ends when the count in the mainframe's Time Base decade reaches its capacity. The decade then outputs a TB OUT pulse. The LOG pulse immediately following sets the MGFF and disables the Main Gate, U13A. During the measurement, the three-state data latch, U5, does not accept any new input data. Its output, however, is enabled periodically by the Low pulse from U4(15). Because of the counting decade in the 5305B, U4 alters the Digital Address codes so the digits are correctly placed in the display. Therefore, the $\Sigma 4$ output goes Low for one count out of eight and switches the latch from its high impedance state to the low impedance (active) state. This occurs for each scan of the display. When the measurement ends, the XFER line enables U4 and new data enters the latch with the next clock pulse from U11(4).

9E-4-16. Frequency Multiplier

9E-4-17. The Frequency Multiplier circuit contains a PLO (Phase-Locked Oscillator) that is used when the RANGE switch is set to the B 10 kHz MAX position. The PLO multiplies the Channel B input frequency by 1000, which means the display's count will be 1000 times higher than normal. Thus, for a 51.234 Hz input and a 1 sec gate time, the counter's display would be 00.051 kHz without the PLO and 51.234 Hz with the PLO. The readout is corrected by changing the annunciator from MHz to kHz or kHz to Hz. The phase detector block diagram is shown in Figure 9E-4-1.

9E-4-18. PHASE DETECTOR. The signal to be measured passes through the channel B amplifier and is applied to pin 1 of U22, a phase/frequency detector. The other input to U22 is the voltage-controlled oscillator's signal, which has been divided by 1000 in U19, 20, and 21. U22 is a TTL device with negative edge-triggered inputs and active low outputs. Under normal, phase-locked operation, the negative edges at the inputs occur at the same moment, and the two outputs are high.

9E-4-19. Under these conditions, the two diodes following the detector (also part of U22) are back-biased and pass no current. Thus, no current enters the integrator amplifier, U23, and its output voltage remains fixed.

Figure 9E-4-1. Phase Detector Block Diagram

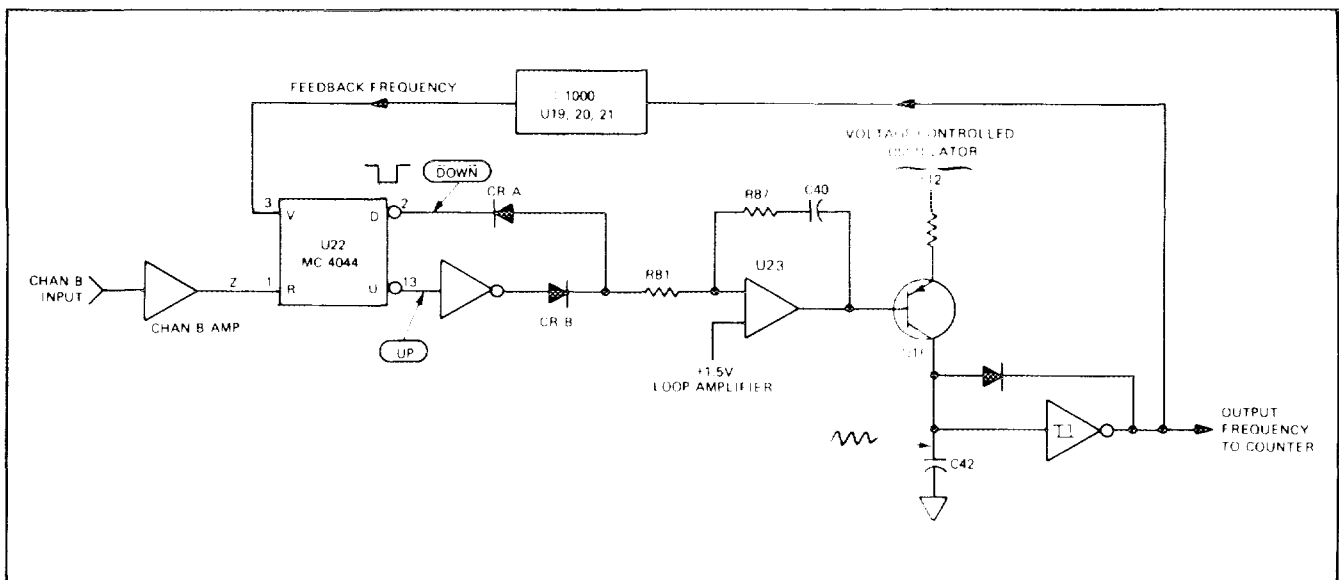

9E-4-20. Assume, however, the channel B frequency increases. This causes the negative pulses at U22(1) to arrive a little earlier than before, arriving ahead of the edges at pin 3. When an edge arrives at pin 1, the UP output goes active low and stays low until the edge at pin 3 arrives. The UP output, then, begins generating active low pulses. They are inverted into positive pulses that forward bias CRB. Current flows through CRB and R81 into the integrator amplifier U23, causing the tuning voltage to integrate downward, this increases the PLO's output and increases the feedback frequency at U22 pin 3. This process continues until the signals at U22 pins 1 and 3 are again matched in frequency and phase. The phase detector outputs are inactive high, and the loop is at reset.

9E-4-21. THE VCO. The phase detector's corrections are integrated and saved by the loop amplifier, an integrating amplifier (refer to A1 schematic). This makes a tuning voltage that sets the frequency of the VCO (voltage-controlled oscillator). The oscillator is a sawtooth generator driving a Schmitt trigger. The voltage-controlled current source (Q16) charges capacitor C42 in a linear ramp until the ramp reaches about +2.4 volts. This goes through an emitter follower (Q17) and appears at U24C(9) at +1.8 volts. This is the upper trigger point on the Schmitt gate. The output of U24C snaps low and discharges C42 through CR21 to about +0.6 volts. This is below the negative threshold, so the Schmitt output snaps high and the sawtooth starts again. The negative pulse train at U24C(8) is used as the PLO output, and it is this frequency that is counted by the decade counter. The waveforms would appear as follows in Figure 9E-4-2.

Figure 9E-4-2. VCO Waveforms at about 2 MHz

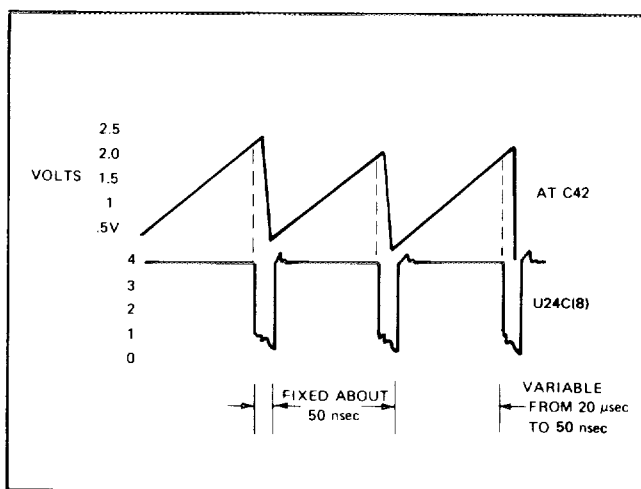

9E-4-22. When the VCO is running at much less than 10 MHz, it becomes very difficult to see the narrow pulses at U24C(8) on a scope. It is easier to see the sawtooth or a squarewave at half the VCO fre-

quency at U21(9). It is important to remember that the frequency/tuning voltage (U23 pin 6) is a negative relationship. That is, the lower the tuning voltage, the higher the frequency.

9E-4-23. SEARCH INDICATOR CIRCUIT. The VCO runs continuously whether the loop is locked (normal operation) or not. In the high resolution range, there is always a signal from the VCO to the 5305B counting circuitry, whether or not there is a signal at the Channel B input. As a result, the counter is always armed and tries to count the VCO frequency (typically 25 kHz) even without an input. This is prevented by the search indicator circuit, U16A, U18C, U24A, Q19.

9E-4-24. When the detector's inputs are in phase, the U22 output pins (2 and 13) are always TTL high. If the loop is not locked, one or the other will be low much of the time. Whenever either is low, U24B(6) is high, signaling an error in the loop. These error pulses are averaged by R77, R78, and C36. If the errors are large enough, the $\overline{\text{LOST}}$ line from comparator U16A will snap low in about 50 msec. In the high resolution range, $\overline{\text{LOST}}$ passes through gate U18C and becomes STOP (active high). STOP lights the SEARCH lamp (S annunciator) through Q14 and gates off the 10 MHz clock at U10A. This prevents the counter from continuing with more measurements or display updates and saves the last valid reading in the display. $\overline{\text{LOST}}$ enables gates U18 B and D, which pass the phase correction signals through resistor R76 (5.1K Ω). R76 is in parallel with R81 (82K Ω), so R81 is effectively reduced from 82K ohm to about 5K ohm. This greatly increases loop bandwidth and allows for rapid searches and short acquisition times.

9E-4-25. When an in-range input signal is restored to Channel B, the loop will lock. The phase corrections stop, U24B(6) (the error signal) stays low, and C36 discharges through R77 (100K ohm). As the average error signal drops through +1 volt, the lower threshold, U16A(1) snaps high, and STOP goes low. U24A(3) inverts this negative edge into a positive edge and Q19 is switched on for about 0.1 seconds. This clears all the counters and the time base, so a new measurement is begun, making the first reading correct. Meanwhile the SEARCH light is switched off, and the loop bandwidth is reduced to a low value to allow proper stability for accurate measurements.

9E-4-26. NON-LINEAR VCO CHARACTERISTIC. When no signal is available at the PLO input, the VCO is tuned to its lowest frequency (about 25 kHz). If a high frequency (e.g., 10 kHz) is applied, the VCO must be slewed all the way to 10,000 kHz to achieve lock. This would take a loop that is stable at 50 Hz almost two minutes to achieve lock. Therefore, gates U18 B and D, were added, and the VCO characteristic has a bend in it. See Figure 9E-4-3.

9E-4-27. This puts a step in the loop bandwidth at about 300 Hz input, increasing loop bandwidth drastically above 300 Hz. (Higher loop bandwidth is allowable at higher input frequencies.) This greatly reduces acquisition time for a 10 kHz input.

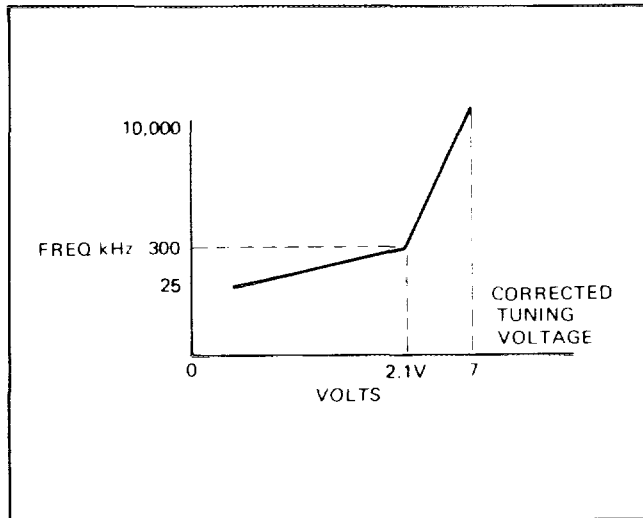

Figure 9E-4-3. VCO Characteristics

9E-4-28. This "bend" in the VCO curve is accomplished by CR24 and R90. The corrected tuning voltage is the voltage between Q16's emitter and the +12 volt supply. The current is set by the resistance between those points. For corrected tuning voltages less than about 2 volts (actual tuning voltage above +9.4 volts), the tri-diode CR24 is off and out of the circuit. The effective resistance is R90 plus R83, or about 6500 ohms. For larger corrected tuning voltages (higher frequencies), the tri-diode is on and shorts R90, removing it from the circuit. Now the effective resistance is R83, or 270 ohms.

9E-4-29. MISCELLANEOUS A1 CIRCUITS. R84 (330K ohm) sets the lowest VCO frequency at about 25 kHz, corresponding to a 25 Hz input. Otherwise, the VCO could actually go to 0 Hz, and the phase detector outputs would go high because the VCO would appear to be locked to a 0 Hz input (no input). This would turn off the search indicator. C47 (100 pF) sets the width of the narrow low-going pulse at the VCO output, U24C(8). Diode CR17 prevents the tuning voltage from going too low when the loop tries to acquire an excessive high input signal (above 11 kHz). Pin 3 of the loop amplifier is biased at +1.5 volts. This forces pin 2 to also be at +1.5V which is a good bias point to allow proper operation of the diode switches.

9E-4-30. 1300 MHz ÷ Circuit

9E-4-31. The A2 board amplifies the Channel A signal and then divides it by four before sending it to A1 via J2(9). U26 divides the EEC1 signal by two before Q18 converts the signal to ECL. Another divide-by-two stage is provided by U25. Differential amplifier Q12 and Q13 converts the signal to a positive driven ECL (V_{CC} = 4.3V, V_E = 3.2V). Q11 provides a low impedance to U12's input.

9E-4-32. A2 1300 MHz AMPLIFIER ASSEMBLY

9E-4-33. The 1300 MHz Amplifier assembly (A2) consists of circuitry to amplify, prescale, and detect signals up to 1300 MHz. Input signals are routed through a protective fuse F1 to the 1.3 GHz limiter circuitry. The limiters consist of CR2, 7, 1, 4 and limit the input to approximately 5V rms. A voltage-controlled attenuator made up of pin diodes CR5, 6, 8, and 9 provides variable attenuation as determined by an AGC circuit.

9E-4-34. The attenuator output connects to U2 which provides 20-24 dB gain. U3 divides the signal by 2 and routes it to U4 where it is divided by 2 again. Since U3 has no Schmitt trigger, U3 is set for maximum sensitivity. Operating at maximum sensitivity gives U3 a tendency to oscillate when no input signal is applied. To maintain high sensitivity and prevent oscillations, R22 is adjusted to desensitize U3 when the ARM line is high and produce high sensitivity when the ARM line is low. This allows the counter readings to "snap on" from no input signal to the exact reading when a signal is applied. The amount of "snap on" feedback is controlled by A1R71. The greater the "snap on" feedback, the less the possibility of partial counts, but also the lower the sensitivity.

9E-4-35. As the input level increases, the level into A2U1 increases. A bridge circuit comprised of CR11, CR12 and associated resistors including R13 which balances the bridge. As the input level to the bridge increases, the rectified bridge output drives the input to U1 to cause the output of U1 to go low. This reduces the amount of current through A1R9, R1 (sen. pot), L4, L1, CR6, CR8, and R11. As the current through this path decreases, the resistance of the PIN diodes (CR6, 8) increases to offer more attenuation to the input signal. Similarly, the current increases through CR9, R10, R1, R3, R6, R7, CR5 and R2, which decreases the resistance of CR5 and CR9 to shunt more of the signal to ground through C5 and C9.

SECTION IX E 5305B 1300 MHz COUNTER

SUBSECTION V MAINTENANCE

9E-5-1. INTRODUCTION

9E-5-2. This subsection contains maintenance information for Model 5300/5305B 1300 MHz Counter. Performance checks, adjustment procedures, and tests to isolate defective components are included.

9E-5-3. RECOMMENDED TEST EQUIPMENT

9E-5-4. Test equipment recommended for performance checking and servicing the 5300B/5305B 1300 MHz Counter is listed in Table 9E-1-1 and in Table 5-1 in the 5300B portion of the manual. Test equipment with equivalent characteristics may be substituted for listed equipment.

9E-5-5. IN-CABINET PERFORMANCE CHECK

9E-5-6. Use the performance check in Table 9E-5-1 and the test card at the back of this subsection to verify proper operation of all circuits in the counter and all circuits in the 5300 that are used with the counter plug-on. The performance check may be used:

- a. As part of an incoming inspection check of instrument specifications.
- b. Periodically, for instruments used in systems where maximum reliability is important.
- c. As part of a procedure to locate defective circuits.
- d. After any repairs of adjustments, before returning instrument to regular service.

9E-5-7. INSTRUMENT ACCESS

9E-5-8. For access to the plug-on assembly, separate the 5300 from the 5305B as follows:

- a. Turn ac power OFF and disconnect power cord.
- b. Pull the two side casting latches fully rearward (it is necessary to press the latch handles gently away from the center of the instrument to unlock them).

- c. When latches are fully extended rearward, the 5300 and 5305B cast housings should be separated by about 1/8-inch.
- d. Lift the 5300 gently away from the 5305B.
- e. Separate 5305B Board Assembly from the cast housing as follows (refer to Figure 9E-5-1):

- (1) Press rear, plastic-nylon retaining clips on each side of 5305B casting and lift the rear of the 5305B Assembly to release it from the casting.
- (2) Press front plastic-nylon retaining clips on each side of 5305B casting and lift the front of the Board Assembly to release it from the casting.
- (3) Lift Board Assembly from the casting.

- f. Mate the 5305B Board Assembly to the 5300 and apply ac power.
- g. To reinstall the Board Assembly into the casting, reverse procedure of steps d through f.

9E-5-9. PERIODIC MAINTENANCE

9E-5-10. To determine if the 5300B/5305B is operating properly, perform the In-Cabinet Performance Checks listed in Table 9E-5-1.

9E-5-11. MAINTENANCE AND REPAIR

9E-5-12. BOARD REMOVAL. When removing the printed circuit board for replacement, repair, or servicing, always remove ac power and separate the board from the casting according to Paragraph 9E-5-8, steps a to e.

9E-5-13. COMPONENT REPLACEMENT. When replacing a circuit board component, use a low heat soldering iron. Heat may be used sparingly as damage to the circuit foil may result. Mounting holes may be cleaned out with a toothpick while heat is applied. Connection should be cleaned with a cleaning solution after component removal and replacement.

Figure 9E-5-1. Separation Procedure

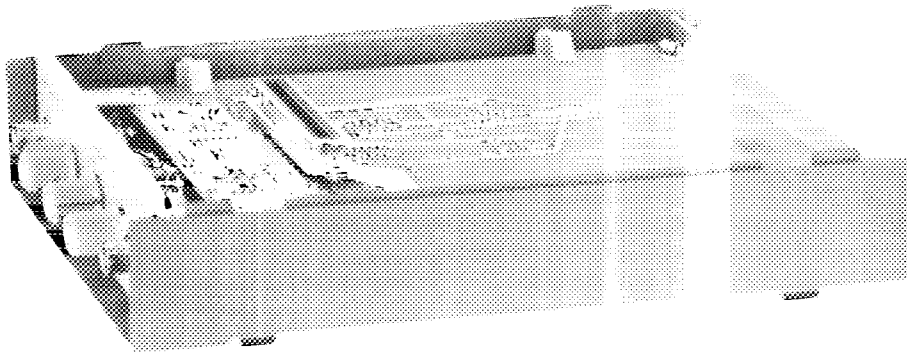

STEP A

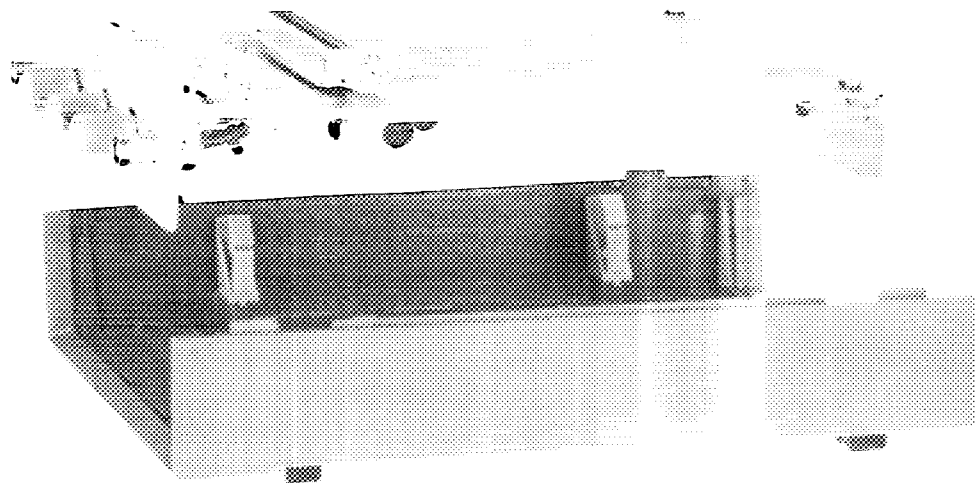

STEP B

Table 9E-5-1. In-Cabinet Performance Check

1. **SELF-CHECK**

Perform Self-Check procedure, Figure 9E-3-3.

2. **CHANNEL A**

Obtain the following test equipment:

HP 8660B/86602A Synthesized Signal Generator

- a. On 5305B, set RANGE to A, RESOLUTION to 1K, and ATTENUATOR to MIN.
- b. Set signal generator to 90 MHz at 20 mV.
- c. Connect 8660B/86602A Signal Generator output to 90 MHz to 1300 MHz jack of 5305B.
- d. Check frequencies in band of 90 to 1300 MHz. Counter should display selected frequency. Count light (C) must be flashing.
- e. Set ATTENUATOR control to MAX. Counter should stop counting.

3. **CHANNEL B**

Obtain the following test equipment:

HP 651B Test Oscillator

HP 8660B/86602A Synthesized Signal Generator

HP 11048A 50-ohm Feed-Thru Termination

- a. On 5305B, set RANGE to B and RESOLUTION to 100 Hz.
- b. Set 8660B/86602A Signal Generator to 100 MHz at 20 mV.
- c. Connect signal generator output to 100 MHz jack of 5305B using 50-ohm feed-thru.
- d. Check frequencies in band of 100 MHz down to 1 MHz. Counter should display selected frequency. Count light (C) must be flashing.
- e. Disconnect signal generator and connect a 651B test oscillator. Retain 50-ohm feed-thru.
- f. On 5305B, set RESOLUTION to 1 kHz.
- g. Set 651B to 1 MHz at 20 mV.
- h. Check frequencies in band of 1 MHz down to 50 Hz. Counter should display selected frequency. Count light (C) must be flashing.
- i. At 50 Hz, counter should display 00000.050 kHz.
- j. On 5305B, set RANGE to B 10 kHz MAX.
- k. The S light should light momentarily, and the display should read (display all 8's). Counter should then display 00050.000 Hz. Count light (C) must be flashing.

PERFORMANCE CHECK TEST CARD

Hewlett-Packard Model 5305B 1300 MHz COUNTER		Test Performed by:
Serial No.		Date:
Description		Check
1.	SELF CHECK	<input type="checkbox"/>
2.	CHANNEL A	<input type="checkbox"/>
	Sensitivity (20 mV)	<input type="checkbox"/>
	Frequency Range (90-1300 MHz)	<input type="checkbox"/>
	Attenuator	<input type="checkbox"/>
3.	CHANNEL B	<input type="checkbox"/>
	Sensitivity (20 mV)	<input type="checkbox"/>
	Frequency (50 Hz-100 MHz)	<input type="checkbox"/>
	High Resolution Mode	<input type="checkbox"/>

9E-5-14. INTEGRATED CIRCUIT REPLACEMENT.
Two methods are recommended for removing integrated circuits:

- a. Solder Gobbler. Solder is removed from board by a soldering iron with a hollow tip connected to a vacuum source. The IC is removed intact, so it may be reinstalled if diagnosis is wrong.
- b. Clip Out. This method is used when an IC is proven defective. Clip leads close to case, apply heat, and remove leads with long-nose pliers. Clean board holes with toothpick and cleaning solution.

9E-5-15. ADJUSTMENTS

9E-5-16. The 5305B has two adjustments; Channel A and Channel B. The adjustments should be made when the in-cabinet performance test indicates the need, or when repairs are made which would affect the adjustment settings.

9E-5-17. CHANNEL A ADJUSTMENTS

9E-5-18. The following steps outline proper adjustment procedure for the Channel A amplifier.

- a. On 5305B, set RANGE to A, RESOLUTION to 1K, and ATTENUATOR to MIN.

- b. Set A2R13 and A1R71 to full ccw. Set A2R22 to midrange.
- c. Connect 5300B/5306A voltmeter positive lead to J2 pin 5 and negative lead to rear panel.
- d. Adjust A1R79 for 15V reading.
- e. Connect test setup shown in Figure 9E-5-2.

NOTE

If meter on 8660B/86602A is calibrated, a 3 foot coaxial cable may be substituted for the power splitter and power meter. Determine the drop in cable (≈ 1 dB).

- f. Set signal generator to 1.29999999 GHz at 30 mV.
- g. Adjust A2R22 for maximum sensitivity. (Reduce signal level until A2R22 is adjusted for maximum sensitivity.)
- h. Set signal generator to 90 MHz.
- i. If counter displays a steading reading of 00270.XXX MHz, adjust output level of generator until counter reads 00268.XXX MHz.
- j. Adjust A1R71 cw until count light (C) stops blinking.

Figure 9E-5-2. Test Setup for 1300 MHz Adjustment

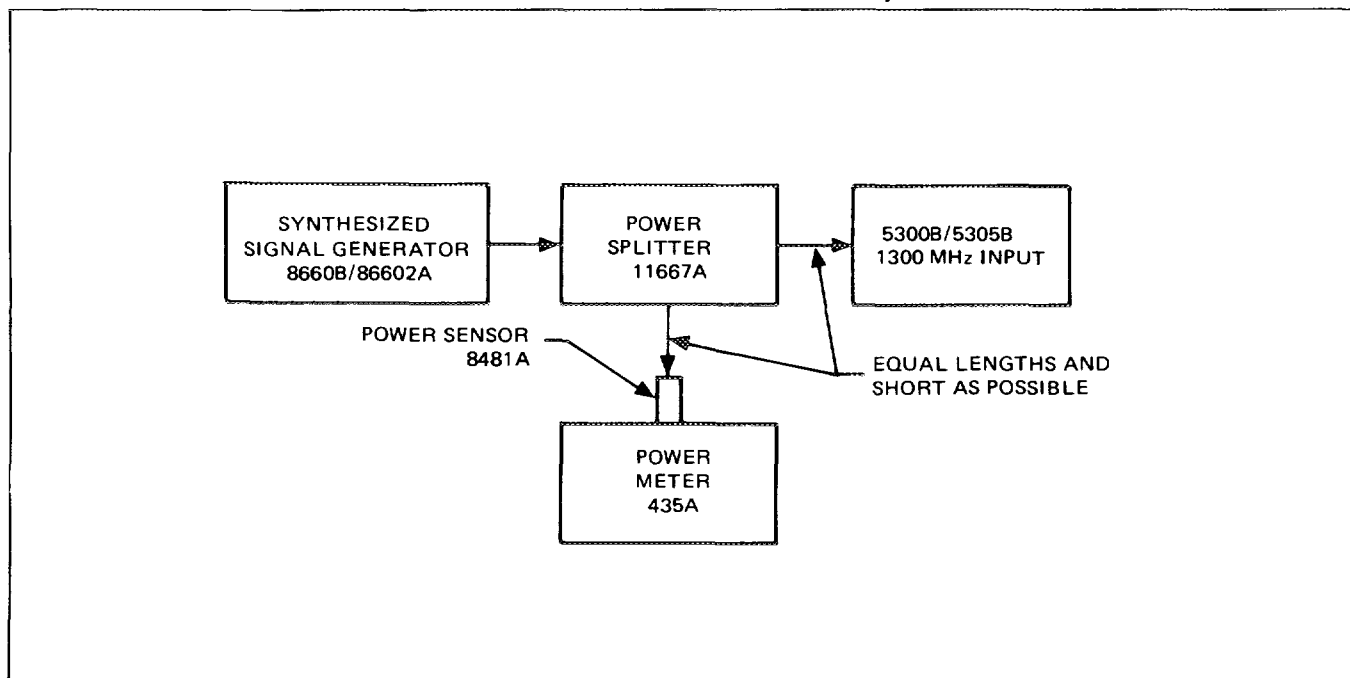

- k. Slowly increase generator output level and observe counter display. 5305B must never count 00180.XXX MHz. If it does, adjust A1R71 cw until count light (C) stops blinking.
- l. Set generator output to 1.29999999 GHz at -21 dBm as measured on power meter. 5305B should count 01299.999 MHz ± 1 count.
- m. Reduce generator level until counter barely counts 01299.999 MHz ± 1 count.
- n. Adjust A1R71 cw if 5305B ambiguity is greater than ± 1 count.
- o. Adjust A2R22 cw until counter barely counts 01299.999 MHz ± 1 count.
- r. Input power to 5305B should be ≤ -21 dBm.
- q. Set input level to -21 dBm and scan frequency down to 90 MHz. Counter should display same reading as 8660B ± 1 count.
- r. Set generator to 90 MHz at -5 dBm.
- s. Connect 5306A voltmeter to TPG and adjust A2R13 cw until 5306A reads +12V ± 1 V.

9E-5-19. CHANNEL B ADJUSTMENTS

9E-5-20. The following steps outline proper adjustment procedure for Channel B amplifier.

- a. On 5305B, set RANGE to B and RESOLUTION to 1 Hz.
- b. Set A1R44 to midrange and A1R18 to full cw.
- c. Set 651B Test Oscillator to 50 Hz at 3V rms and connect directly to 100 MHz input on 5305B.
- d. Measure AGC voltage at TPA with 5300B/5306A voltmeter.
- e. Adjust A1R44 for 1.75V reading on voltmeter.

SERVICE NOTE

AGC voltage should decrease when level of input signal is reduced. With no input signal, AGC voltage should be negative.

- f. Disconnect 651B Test Oscillator.
- g. On 5305B, set RANGE to B and RESOLUTION to 10 Hz.

- h. Set 8660B/86602A Signal Generator to 100 MHz at ≈ 2 mV and connect output of generator to 100 MHz input using a 50-ohm feed-thru.
- i. Increase generator level until counter displays stable 100 MHz ± 1 count.
- j. Adjust A1R18 cw to point where 5305B barely continues to make measurements. (Any more cw rotation will stop gating.)
- k. Input signal must be 20 mV or below.

9E-5-21. TROUBLESHOOTING

9E-5-22. Use the following troubleshooting information, the waveforms, and schematic diagram in subsection VIII to isolate troubles in the counter to a defective component.

9E-5-23. If a malfunction is suspected, operate the counter in the self-check mode (see Figure 9E-3-3) and analyze the front-panel indicators for evidence of improper operation. Some troubles can be quickly isolated in this manner. The self-check procedure exercises most of the counter circuits; the input circuits for both channels are notable exceptions.

9E-5-24. To determine if a problem exists in both input channels or just one channel, then perform the appropriate troubleshooting procedure. Be sure to perform each step in sequence. The following test equipment is required:

- a. HP 10525T Logic Probe
- b. HP 180A/1801A/1821A Oscilloscope
- c. HP 651B Test Oscillator
- d. HP 8660B/86602A Synthesized Signal Generator

9E-5-25. 100 MHz Channel Troubleshooting

9E-5-26. Set the RESOLUTION switch to 1 kHz and the RANGE switch to 100 MHz. Supply a 9 kHz, 1-volt sinusoidal input to the channel. Perform the following steps:

- a. Check output of Channel B at A1U6(3). See waveform photos in Subsection VIII.
- b. If proper signal is not present, compare waveforms with those provided in Subsection VIII.
- c. If proper signal is present, check operation of U12C.

9E-5-27. 1300 MHz Channel Troubleshooting

9E-5-28. Set the RESOLUTION switch to 1 kHz and the RANGE switch to A. Supply a 100 MHz, 25-millivolt, sinusoidal input to the channel and perform the following steps.

- a. Check the EECL output of A2 at A2 pin 9 with oscilloscope. See waveform photos in Subsection VIII.
- b. If signal is not present at pin 9, check input fuse located in front panel jack before troubleshooting the assembly. See Subsection VIII for dc checks of A2.
- c. If proper signal is present at A2 pin 9, check operation of U26, U25, Q13, Q11, and U12 on the A1 board.

9E-5-29. Both Channels Inoperative

9E-5-30. Set RESOLUTION switch to 1 Hz position, RANGE switch to B, and apply 1 MHz sinusoidal input to the 100 MHz channel from a 651B Test Oscillator.

- a. If any digit is blank, proceed to "Address Decoder Troubleshooting" in Paragraph 9E-5-31, also, at this time, note the unique displays listed under that heading.
- b. If only the least-significant digit is displayed, and all others are zero, check U13C, Q9, and Q10.
- c. If only decimal point problems occur, check A1P1 (34, 46, 47, and 48) and the RESOLUTION switch.
- d. Check U13A(5) for presence of input signal using oscilloscope. If not present, check operation of selected NOR gate responsible for passing signal.
- e. Check for presence of clock signal at U10B(6). (U9A pin 3 should be a TTL low during gate time to pass clock pulses. If not, check input at U9A(1). If input does not toggle, continue to next step.
- f. Using an oscilloscope, check that U17A(2) toggles (should be low ($\approx 3.2V$) during gate time). If not, check U17, Q7, and Q8.
- g. With an oscilloscope, check that outputs of U14 are toggling (indication of counting).
- h. Check that CLOSE line toggles. If not, check U17B, U16D, and CR10.

9E-5-31. ADDRESS DECODER TROUBLESHOOTING. Because the 5305B contains one decade of information, the Digit Address lines that strobe data onto the display must be altered to accommodate the extra digit. These code lines are altered in A1U4 and sent to the mainframe as Digit Select lines.

9E-5-32. The following table shows the display results when one of U4's outputs is stuck in one logic state. Important: set RESOLUTION switch to 10 kHz and use 1.25 MHz input signal.

Table 9E-5-2. Erroneous Displays Caused by U4

Shorted to Ground	Display
$\Sigma 3$ (pin 2)	012.00120 MHz
$\Sigma 2$ (pin 6)	000.12120 MHz
$\Sigma 1$ (pin 9)	000.00220 MHz
$\Sigma 4$ (pin 15)	000.00105 MHz
Stuck High	Display
$\Sigma 3$ (pin 2)	000.b0005 MHz
$\Sigma 2$ (pin 6)	b00.00005 MHz
$\Sigma 1$ (pin 9)	b00.00115 MHz
$\Sigma 4$ (pin 15) (or outputs of U5 are inactive)	000.0012b MHz

b = blank

9E-5-33. Compare waveforms with those provided in Section VIII. $\Sigma 4$ should be low for 1/8 of the period. The code for U4 appears as shown below.

A3	A2	A1	$\Sigma 4$	$\Sigma 3$	$\Sigma 2$	$\Sigma 1$
L	L	L	L	H	H	H
L	L	H	H	L	L	L
L	H	L	H	L	L	H
L	H	H	H	L	H	L
H	L	L	H	L	H	H
H	L	H	H	H	L	L
H	H	L	H	H	L	H
H	H	H	H	H	H	L

9E-5-34. Frequency Multiplier

9E-5-35. Before troubleshooting the Frequency Multiplier circuit, ensure the Channel B amplifier is working properly. Apply a 1 kHz, 100 mV signal to Channel B; set RANGE to B 10 kHz MAX and RESOLUTION to 1 Hz.

- a. Check input to PLO at U22(1). It should be a 1 kHz square wave. If not, check U16B(2).
- b. Check supplies: +5V on U21(14), U24(14); +12V at U23(7).

c. Check Loop Amplifier U23. For a 1 kHz input U23(6) should be about +9V to +10V. If it is +11V or higher, the loop responds as if the VCO output frequency is too high. This is true when the loop is receiving no input at U22(1). If U23(6) is low (about +4 volts), the loop responds as if the VCO frequency is too low and tries to increase it. This would indicate a bad VCO (U24 pin 8) or a bad ± 1000 chain (U21, U20, and U19).

9E-5-36. VOLTAGE-CONTROLLED OSCILLATOR. To check the VCO, connect an oscilloscope to U21(9). There should be a square wave at half the VCO frequency. For a 1 kHz input, the VCO output should be 1 MHz, 1000 times the input. The VCO should run between 25 kHz (U23-6 at +11 volts) and 11 MHz (U23-6 at +4 volts). If a square wave appears at U21(9) from 12 kHz to 5.5 MHz, the frequency should relate roughly to the voltage at U23-6. If not, probably trouble is in circuitry associated with Q16, R83, C42 or U24(9). If there is no indication at U21-9, check the same circuits. Also, check that U23(6) is above +4 volts otherwise the VCO tends to shut off. CR17 should prevent this.

9E-5-37. If there is no indication at U21(9), connect the scope to U24(9) and check for the following sawtooth voltage at the output frequency.

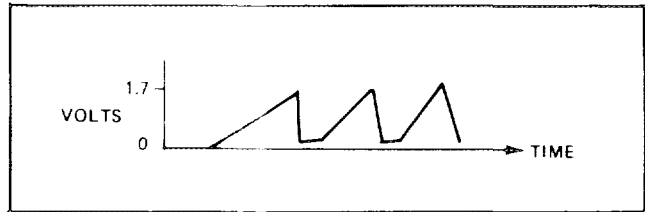

9E-5-38. If the waveform is improper, the VCO is faulty. If the signal is present, and not at U21(9), U21 probably is bad. If the signal is between 12 kHz and 5 MHz at U21(9), there should be 1/500 of that at U22(3). If not, U19, U20 and/or U21 are faulty.

9E-5-39. DETECTOR CIRCUIT. Check U23(3); it should be at +1.5 volts $\pm .3$ volts. A problem here will saturate U23. Now test U22, the detector. If U22(1) has a faster frequency than U22(3), U22(13) should be low part or all of the time at a rate similar to that at U22(3). U22(2) should always be TTL high ($\approx +3.5V$).

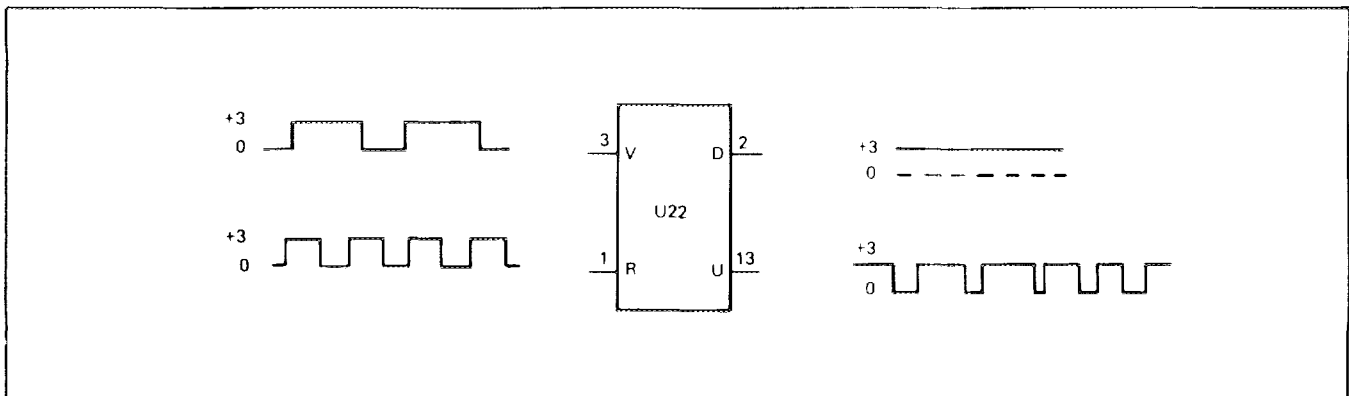

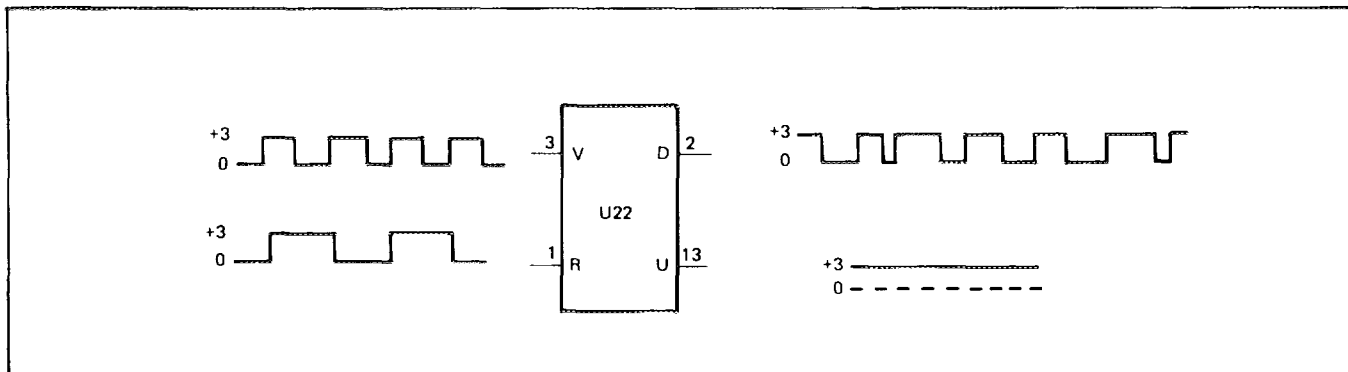

9E-5-40. If the reserve is true, i.e., the frequency at U22(3) is greater than U22(1), then U22(2) should pulse low (or stay low if nothing at pin 1), and U22(13) should always be high. Pins 2 and 13 can never be low together.

9E-5-41. "S" LIGHT ON, NO MEASUREMENTS. It is possible that the PLO is working properly but no measurements are made. If the negative edges of the signals at U22(1 and 3) match, the PLO is working properly. U22(2 and 13) should be high almost all the time, and U24(6) should be low almost always (small positive pulses). Then U16(1) (LOST) should be at TTL 1 (+5 volts). If not, there is something wrong with it or associated parts R77, R78, R59, R61, R62, R70 or R36. Also, U18(10) (STOP) should be low. When STOP is high, counter operation is frozen by stopping the clock at U10(13), and the "S" light is lit.

9E-5-42. FAULTY DISPLAYS WITH NO INPUT. When the input is disconnected, the display should hold last reading, if not check the stop circuits (U24, U16, and U18).

9E-5-43. INCORRECT FIRST READING. The first measurement after a signal is applied should be accurate. If way off, the reset circuit Q19 is not working. About 1/2 second after a signal is applied, U18(10) should go low, U24(3) should go high and Q19 should saturate for about 1/10 second. This should pull J1-32 (50 pin connector) low and the system should "manual

reset". All 8's should show in the display (5300B) for 1/10 second, then 0's until new measurement displayed at end of gate time. If not, there are problems around Q19, R91, R92, R93 or C48.

9E-5-44. SLOW ACQUISITION. If the 5305B takes more than about 1 second to make a measurement (plus gate time) after a signal is applied to the PLO, circuit problems exist. With no signal, check that U16(1) is low (LOST). U18 should be enabled, and low rate (25 Hz) pulses should appear at U18(1) (same as of U22 pin 2). Connect a 20 kHz signal and check for pulses at U18(13). The S light should be on during this time. Check CR16 and CR18. If CR24 (a tri-diode) is open, tuning will be slow and the upper frequency limit will be very low. If CR20 and CR22 are open, the loop will be slightly erratic.

9E-5-45. NOT ENOUGH RANGE (10 kHz). If the PLO will not measure high frequencies (10 kHz), check CR24 and ensure proper values of R83, C42, and C47. The tuning voltage at U23(6) should be about +4V at the highest frequency. Also, check the +12V supply.

9E-5-46. POOR LOW-FREQUENCY RANGE. If the counter does not measure low frequency (50 Hz), check Q16 for leakage. Ensure that U23(6) can pull voltage high enough (Q16 should be off at the lower frequency limit). Check C49, C47, and CR21 and check for +1.5V at U23(3).

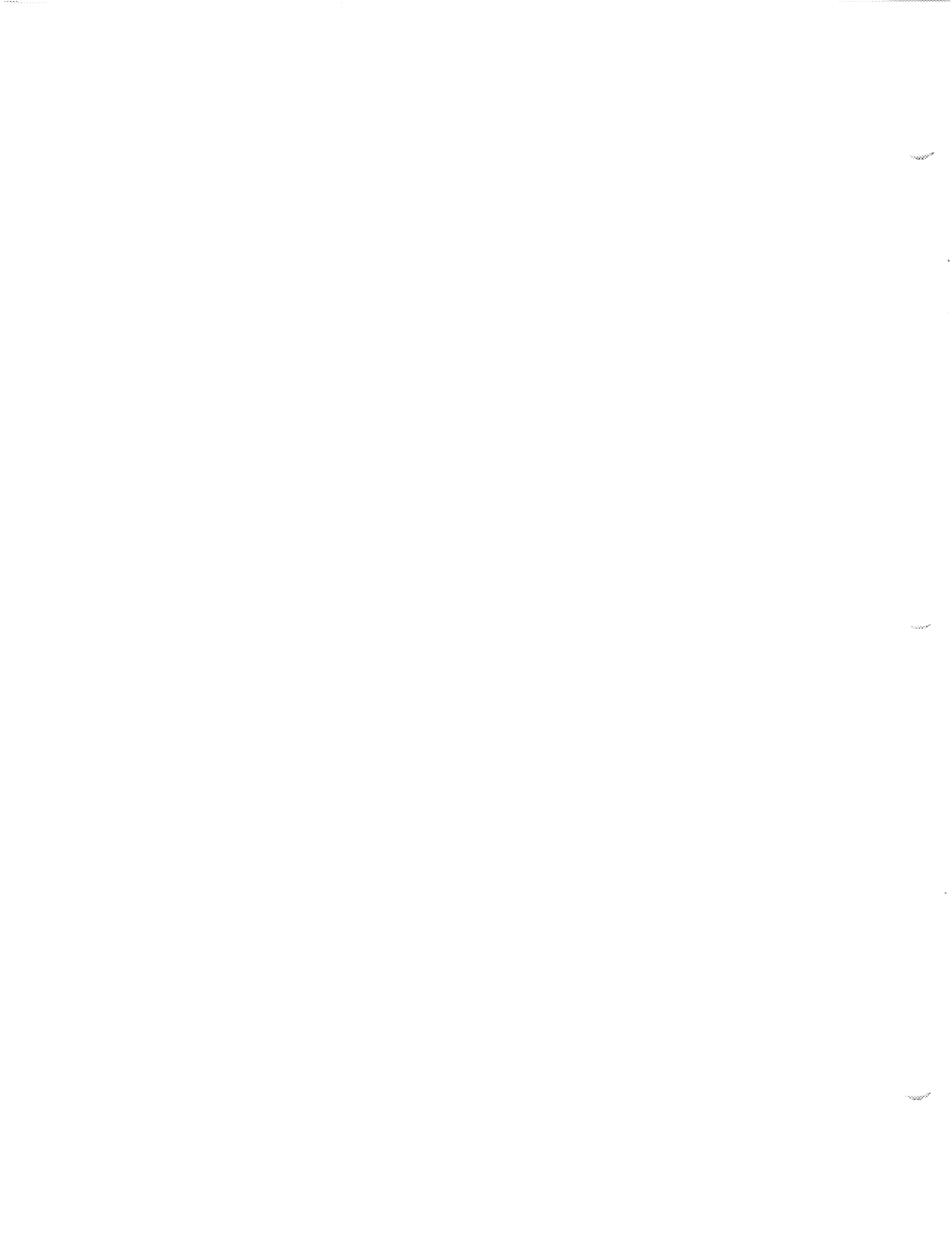

SECTION IX E 5305B 1300 MHz COUNTER

SUBSECTION VI REPLACEABLE PARTS

9E-6-1. INTRODUCTION

9E-6-2. This subsection contains information for ordering replacement parts. Table 9E-6-1 lists parts used in the standard counter in alphanumeric order of their reference designators and provides the following information for each part. Table 9E-6-2 lists parts used in Option 001. Miscellaneous parts are listed at the end of Table 9E-6-1.

- a. Hewlett-Packard part number.
- b. Description of part (see abbreviation below).
- c. Total quantity used in the instrument (shown only after the first entry for a given part).
- d. Typical manufacturer of the part in a five-digit code (see list of manufacturer's in Table 9E-6-2).
- e. Manufacturer's part number.

9E-6-3. ORDERING INFORMATION

9E-6-4. To obtain replacement parts, address order to your local Hewlett-Packard Sales and Service Office (see lists in Section VI of the 5300 manual for addresses). Identify parts by their Hewlett-Packard part number. To obtain a part that is not listed, include:

- a. Instrument model number.
- b. Instrument serial number.
- c. Description of the part.
- d. Function and location of the part.

REFERENCE DESIGNATIONS					
<p>A = assembly</p> <p>AT = attenuator; isolator, termination</p> <p>B = fan, motor</p> <p>BT = battery</p> <p>C = capacitor</p> <p>CP = coupler</p> <p>CR = diode, diode thyristor, varactor</p> <p>DC = directional coupler</p> <p>DL = delay line</p> <p>DS = annunciator; signaling device (audible or visual); lamp; LED</p>	<p>E = miscellaneous electrical part</p> <p>F = fuse</p> <p>FL = filter</p> <p>H = hardware</p> <p>HY = circulator</p> <p>J = electrical connector (stationary portion), jack</p> <p>K = relay</p> <p>L = coil, inductor</p> <p>M = meter</p>	<p>MP = miscellaneous mechanical part</p> <p>P = electrical connector (movable portion); plug</p> <p>Q = transistor, SCR, triode thyristor</p> <p>R = resistor</p> <p>RT = thermistor</p> <p>S = switch</p> <p>T = transformer</p> <p>TB = terminal board</p> <p>TC = thermocouple</p>	<p>TP = test point</p> <p>U = integrated circuit, microcircuit</p> <p>V = electron tube</p> <p>VR = voltage regulator, breakdown diode</p> <p>W = cable; transmission path, wire</p> <p>X = socket</p> <p>Y = crystal unit-piezoelectric</p> <p>Z = tuned cavity, tuned circuit</p>		
ABBREVIATIONS					
<p>A = ampere</p> <p>ac = alternating current</p> <p>ACCESS = accessory</p> <p>ADJ = adjustment</p> <p>A/D = analog-to-digital</p> <p>AF = audio frequency</p> <p>AFC = automatic frequency control</p> <p>AGC = automatic gain control</p> <p>AL = aluminum</p> <p>ALC = automatic level control</p> <p>AM = amplitude modulation</p> <p>AMPL = amplifier</p> <p>APC = automatic phase control</p> <p>ASSY = assembly</p> <p>AUX = auxiliary</p> <p>avg = average</p> <p>AWG = american wire gauge</p> <p>BAL = balance</p>	<p>BCD = binary coded decimal</p> <p>BD = board</p> <p>BE CU = beryllium copper</p> <p>BFO = beat frequency oscillator</p> <p>BH = binder head</p> <p>BKDN = breakdown</p> <p>BP = bandpass</p> <p>BPF = bandpass filter</p> <p>BRS = brass</p> <p>BWO = backward-wave oscillator</p> <p>CAL = calibrate</p> <p>ccw = counterclockwise</p> <p>CER = ceramic</p> <p>CHAN = channel</p> <p>cm = centimeter</p> <p>CMO = coaxial</p> <p>COEF = coefficient</p> <p>COM = common</p>	<p>COMP = composition</p> <p>COMPL = complete</p> <p>CONN = connector</p> <p>CP = cadmium plate</p> <p>CRT = cathode-ray tube</p> <p>CTL = complementary transistor logic</p> <p>CW = continuous wave</p> <p>cw = clockwise</p> <p>D/A = digital-to-analog</p> <p>dB = decibel</p> <p>dBm = decibel referred to 1 mW</p> <p>dc = direct current</p> <p>deg = degree (temperature interval or difference)</p> <p>...° = degree (plane angle)</p> <p>°C = degree Celsius (centigrade)</p> <p>°F = degree Fahrenheit</p>	<p>°K = degree Kelvin</p> <p>DEPC = deposited carbon</p> <p>DET = detector</p> <p>diam = diameter</p> <p>DIA = diameter (used in parts list)</p> <p>DIFF = differential amplifier</p> <p>AMPL = division</p> <p>div = division</p> <p>DPDT = double-pole, double-throw</p> <p>DR = drive</p> <p>DSB = double sideband</p> <p>DTL = diode transistor logic</p> <p>DVM = digital voltmeter</p> <p>ECL = emitter coupled logic</p> <p>EMF = electromotive force</p> <p>EDP = electronic data processing</p> <p>ELECT = electrolytic</p>		

ABBREVIATIONS (CONTINUED)

ENCAP	encapsulated	min	minute (time)	PIV	peak inverse voltage	TFT	thin film transistor
EXT	external		minute (plane angle)	pk	peak	TGL	toggle
F	farad	MINAT	miniature	PL	phase lock	THD	throat
FET	field effect transistor	mm	millimeter	PLO	phase lock oscillator	THRU	through
F/F	flip-flop	MOD	modulator	PM	phase modulation	TI	titanium
FH	flat head	MOM	momentary	PNP	positive negative	TOL	tolerance
FOL H	filister head	MOS	metal oxide semi conductor	P.O	part of	TRIM	trimmer
FM	frequency modulation	ms	milisecond	POLY	polystyrene	TSTR	transistor
FP	front panel	MTG	mounting	PORC	porcelain	TTL	transistor transistor logic
FREQ	frequency	MTR	meter indicating device	POS	positive (potential) based in parts list	TV	television
FXD	fixed		millivolt	POSN	position	TVI	television interference
g	gram	mV	millivolt	POT	potentiometer	TWT	traveling wave tube
GE	germanium	mVac	millivolt ac	p-p	peak to peak	U	micro (10 ⁻⁶) (used in parts list)
GHz	gigahertz	mVdc	millivolt dc	PP	peak to peak (used in parts list)	UF	microfarad (used in parts list)
GL	glass	mVpk	millivolt peak	PPM	pulse position modulation	UHF	ultrahigh frequency
GND	ground(ed)	mVp-p	millivolt peak to peak	PREAMPL	preamplifier	UNREG	unregulated
H	henry	mVrms	millivolt rms	PRF	pulse repetition frequency	V	volt
h	hour	mW	milliwatt	ps	pulse repetition rate	VA	voltampere
HET	heterodyne	MUX	multiplex	PT	point	Vac	volts ac
HEX	hexagonal	MY	mylar	PTM	pulse time modulation	VAR	variable
HD	head	μA	microampere	PWM	pulse width modulation	VCO	voltage controlled oscillator
HDW	hardware	μF	microfarad	PWV	peak working voltage	Vdc	volts dc
HF	high frequency	μH	microhenry	RC	resistance capacitance network	VDCW	volts dc working (used in parts list)
HG	mercury	μmho	micromho	RECT	rectifier	VfF	volts, filtered
HI	high	μs	microsecond	REF	reference	VFO	variable frequency oscillator
HP	Hewlett Packard	μV	microvolt	REG	regulated	VHF	very high frequency
HPF	high pass filter	μVac	microvolt, ac	REPL	replaceable	Vpk	volts peak
HR	hour (used in parts list)	μVdc	microvolt, dc	RF	radio frequency	Vp p	Volts peak to peak
HV	high voltage	μVpk	microvolt peak	RFI	radio frequency interference	Vrms	volts rms
HZ	Hertz	μVp-p	microvolt, peak to peak	RH	rod head right hand	VSWR	voltage standing wave ratio
IC	integrated circuit	μVrms	microvolt rms	RLC	resistance inductance capacitance	VTO	voltage tuned oscillator
ID	inside diameter	μW	microwatt	RMO	rack mount rack	VIVM	vacuum tube voltmeter
IF	intermediate frequency	nA	nanampere	rms	rms	VIX	volts switched
IMPG	impregnated	NC	no connection	RND	round	W	watt
in	inch	NC	normally closed	ROM	read only memory	W	with
INCD	incandescent	NE	neon	R&P	rack and panel	WIV	working inverse voltage
INCL	include(s)	NEG	negative	RWV	reverse working voltage	WW	wirewound
INP	input	nF	nanofarad	S	scattering parameter	W O	without
INS	insulation	NI PL	nickel plate	S	second (time)	YIG	yttrium iron garnet
INT	internal	N.O	normally open	S	second (plane angle)	Zo	characteristic impedance
kg	kilogram	NORM	normal	S B	show blow thru (used in parts list)		
kHz	kilohertz	NPN	negative positive negative	SCR	silicon controlled rectifier, series		
kΩ	kilohm	NPO	negative positive zero (zero temperature coefficient)	SE	semium		
kV	kilovolt	NRFR	not recommended for field replacement	SECT	sections		
lb	pound	NSR	not separately replaceable	SEMICON	semiconductor		
LC	inductance capacitance	ns	nanosecond	SHF	super high frequency		
LED	light emitting diode	nW	nanowatt	SI	silicon		
LF	low frequency	OBD	order by description	SIL	silver		
LG	long	OD	outside diameter	SL	slide		
LH	left hand	OH	oval head	SNR	signal to noise ratio		
LIM	limit	OP AMPL	operational amplifier	SPDT	single pole double throw		
LIN	linear taper (used in parts list)	OPT	option	SPG	spring		
lin	linear	OSC	oscillator	SR	split ring		
LK WASH	lockwasher	OX	oxide	SPST	single pole single throw		
LO	low local oscillator	oz	ounce	SSB	single sideband		
LOG	logarithmic taper (used in parts list)	Ω	ohm	SST	stainless steel		
log	logarithmic	P	peak (used in parts list)	STL	steel		
LPF	low pass filter	PAM	pulse amplitude modulation	SO	square		
LV	low voltage	PC	printed circuit	SWR	standing wave ratio		
m	meter (distance)	PCM	pulse code modulation	SYNC	synchronization		
mA	milliamper	PDM	pulse duration modulation	T	timed (slow blow fuse)		
MAX	maximum	pF	picofarad	TA	tantalum		
MΩ	megohm	PH BRZ	phosphor bronze	TC	temperature compensation		
MEG	meg (10 ⁶) (used in parts list)	PIN	positive intrinsic negative	TD	time delay		
MET FLM	metal film			TERM	terminal		
MET OX	metal oxide						
MF	medium frequency, microfarad (used in parts list)						
MFR	manufacturer						
mg	milligram						
MHz	megahertz						
mH	millihenry						
mho	mho						
MIN	minimum						

NOTE

All abbreviations in the parts list will be in upper case.

MULTIPLIERS

Abbreviation	Prefix	Multiple
T	tera	10 ¹²
G	giga	10 ⁹
M	mega	10 ⁶
k	kilo	10 ³
da	deka	10
d	deci	10 ⁻¹
c	centi	10 ⁻²
m	milli	10 ⁻³
μ	micro	10 ⁻⁶
n	nano	10 ⁻⁹
p	pico	10 ⁻¹²
f	femto	10 ⁻¹⁵
a	atto	10 ⁻¹⁸

Table 9E-6-1. Replaceable Parts

Reference Designation	HP Part Number	Qty	Description	Mfr Code	Mfr Part Number
A1	05305-60005	1	BOARD ASSY, LOGIC	28480	05305-60005
A1C1	0160-4084	13	CAPACITOR-FXD .1UF +-20% 50WVDC CER	29480	0160-4084
A1C2	0160-4084		CAPACITOR-FXD .1UF +-20% 50WVDC CER	28480	0160-4084
A1C3	0180-1746	3	CAPACITOR-FXD 15UF+-10% 20VDC TA	56289	1500156X9020B2
A1C4	0150-0075	1	CAPACITOR-FXD 4700PF +100-0% 500WVDC CER	28480	0150-0075
A1C5	0160-3879	11	CAPACITOR-FXD .01UF +-20% 100WVDC CER	28480	0160-3879
A1C6	0160-3879		CAPACITOR-FXD .01UF +-20% 100WVDC CER	28480	0160-3879
A1C7	0160-3456	1	CAPACITOR-FXD 1000PF +-10% 1000WVDC CER	28480	0160-3456
A1C8	0160-4084		CAPACITOR-FXD .1UF +-20% 50WVDC CER	28480	0160-4084
A1C9	0180-1746		CAPACITOR-FXD 15UF+-10% 20VDC TA	56289	1500156X9020B2
A1C10	0180-1746		CAPACITOR-FXD 15UF+-10% 20VDC TA	56289	1500156X9020B2
A1C11	0180-0155	2	CAPACITOR-FXD 2.2UF+-20% 20VDC TA	56289	1500225X0020A2
A1C12	0160-3879		CAPACITOR-FXD .01UF +-20% 100WVDC CER	28480	0160-3879
A1C13	0180-0210	3	CAPACITOR-FXD 3.3UF+-20% 15VDC TA	56289	1500335X0015A2
A1C14	0180-1701	4	CAPACITOR-FXD 6.8UF+-20% 6VDC TA	56289	1500685X0006A2
A1C15*	0160-3873	2	CAPACITOR-FXD 4.7PF +-5PF 200WVDC CER	28480	0160-3873
A1C15*	0160-3872		CAPACITOR-FXD 2.2PF +-25PF 200WVDC CER	28480	0160-3872
A1C15*	0160-3874		CAPACITOR-FXD 10PF +-5PF 200WVDC CER	28480	0160-3874
A1C16	0160-3879		CAPACITOR-FXD .01UF +-20% 100WVDC CER	29480	0160-3879
A1C17	0180-0490	3	CAPACITOR-FXD 68UF+-10% 6VDC TA	56289	1960686X9006KA1
A1C18	0180-0553	1	CAPACITOR-FXD 22UF+-20% 25VDC TA	28480	0180-0553
A1C19	0160-4084		CAPACITOR-FXD .1UF +-20% 50WVDC CER	28480	0160-4084
A1C20	0180-0210		CAPACITOR-FXD 3.3UF+-20% 15VDC TA	56289	1500335X0015A2
A1C21	0180-1702	2	CAPACITOR-FXD 180UF+-20% 6VDC TA	56289	1500187X0006R2
A1C22	0180-1702		CAPACITOR-FXD 180UF+-20% 6VDC TA	56289	1500187X0006R2
A1C23	0180-0210		CAPACITOR-FXD 3.3UF+-20% 15VDC TA	56289	1500335X0015A2
A1C24	0180-0490		CAPACITOR-FXD 68UF+-10% 6VDC TA	56289	1960686X9006KA1
A1C25	0180-1701		CAPACITOR-FXD 6.8UF+-20% 6VDC TA	56289	1500685X0006A2
A1C26	0180-0490		CAPACITOR-FXD 68UF+-10% 6VDC TA	56289	1960686X9006KA1
A1C27	0160-4084		CAPACITOR-FXD .1UF +-20% 50WVDC CER	28480	0160-4084
A1C28	0160-4084		CAPACITOR-FXD .1UF +-20% 50WVDC CER	28480	0160-4084
A1C29	0160-4084		CAPACITOR-FXD .1UF +-20% 50WVDC CER	28480	0160-4084
A1C30	0160-4084		CAPACITOR-FXD .1UF +-20% 50WVDC CER	28480	0160-4084
A1C31	0160-3879		CAPACITOR-FXD .01UF +-20% 100WVDC CER	29480	0160-3879
A1C32	0160-3879		CAPACITOR-FXD .01UF +-20% 100WVDC CER	28480	0160-3879
A1C33	0160-3879		CAPACITOR-FXD .01UF +-20% 100WVDC CER	28480	0160-3879
A1C34	0160-3879		CAPACITOR-FXD .01UF +-20% 100WVDC CER	28480	0160-3879
A1C35	0180-0098	1	CAPACITOR-FXD 100UF+-20% 20VDC TA	56289	1500107X0020S2
A1C36	0180-1701		CAPACITOR-FXD 6.8UF+-20% 6VDC TA	56289	1500685X0006A2
A1C37	0160-4084		CAPACITOR-FXD .1UF +-20% 50WVDC CER	28480	0160-4084
A1C38	0160-3879		CAPACITOR-FXD .01UF +-20% 100WVDC CER	28480	0160-3879
A1C39	0160-4084		CAPACITOR-FXD .1UF +-20% 50WVDC CER	28480	0160-4084
A1C40	0180-0374	1	CAPACITOR-FXD 10UF+-10% 20VDC TA	56289	1500106X9020B2
A1C41	0160-4084		CAPACITOR-FXD .1UF +-20% 50WVDC CER	28480	0160-4084
A1C42	0140-0178	1	CAPACITOR-FXD 560PF +-2% 300WVDC MICA	72136	DM15F561G0300HV1CR
A1C43	0160-4084		CAPACITOR-FXD .1UF +-20% 50WVDC CER	28480	0160-4084
A1C44	0160-3879		CAPACITOR-FXD .01UF +-20% 100WVDC CER	28480	0160-3879
A1C45	0160-3879		CAPACITOR-FXD .01UF +-20% 100WVDC CER	28480	0160-3879
A1C46	0180-0155		CAPACITOR-FXD 2.2UF+-20% 20VDC TA	56289	1500225X0020A2
A1C47	0160-2204	1	CAPACITOR-FXD 100PF+-5% 300WVDC MICA	09023	RD15F101J3C
A1C48	0180-1701		CAPACITOR-FXD 6.8UF+-20% 6VDC TA	56289	1500685X0006A2
A1C49	0160-4084		CAPACITOR-FXD .1UF +-20% 50WVDC CER	28480	0160-4084
A1C50	0180-0195	1	CAPACITOR-FXD .33UF+-20% 35VDC TA	56289	1500334X0035A2
A1CR1	1910-0016	4	DIODE-GE 60V 60MA 1US DO-7	28480	1910-0016
A1CR2	1901-0179	7	DIODE-SWITCHING 15V 50MA 750PS DO-7	28480	1901-0179
A1CR3	1902-0025	1	DIODE-ZNR 10V 5% DO-7 PD=.4W TC=+.06%	04713	SZ 10939-182
A1CR4	1901-0179		DIODE-SWITCHING 15V 50MA 750PS DO-7	28480	1901-0179
A1CR5	1901-0179		DIODE-SWITCHING 15V 50MA 750PS DO-7	28480	1901-0179
A1CR6	1901-0040	8	DIODE-SWITCHING 30V 50MA 2NS DO-35	28480	1901-0040
A1CR7	1901-0179		DIODE-SWITCHING 15V 50MA 750PS DO-7	28480	1901-0179
A1CR8	1901-0040		DIODE-SWITCHING 30V 50MA 2NS DO-35	28480	1901-0040
A1CR9	1901-0535	5	DIODE-SCHOTTKY	28480	1901-0535
A1CR10	1910-0016		DIODE-GE 60V 60MA 1US DO-7	28480	1910-0016
A1CR11	1901-0535		DIODE-SCHOTTKY	28480	1901-0535
A1CR12	1901-0535		DIODE-SCHOTTKY	28480	1901-0535
A1CR13	1901-0535		DIODE-SCHOTTKY	28480	1901-0535
A1CR14	1901-0028	2	DIODE-PWR RECT 400V 750 MA DO-29	04713	SR1358-9
A1CR15	1901-0040		DIODE-SWITCHING 30V 50MA 2NS DO-35	28480	1901-0040
A1CR16	1901-0040		DIODE-SWITCHING 30V 50MA 2NS DO-35	28480	1901-0040
A1CR17	1901-0040		DIODE-SWITCHING 30V 50MA 2NS DO-35	28480	1901-0040
A1CR18	1901-0040		DIODE-SWITCHING 30V 50MA 2NS DO-35	28480	1901-0040
A1CR19	1901-0040		DIODE-SWITCHING 30V 50MA 2NS DO-35	28480	1901-0040
A1CR20	1910-0016		DIODE-GE 60V 60MA 1US DO-7	28480	1910-0016

*FACTORY SELECTED PART

See introduction to this section for ordering information

Table 9E-6-1. Replaceable Parts (Cont'd)

Reference Designation	HP Part Number	Qty	Description	Mfr Code	Mfr Part Number
A1CR21	1901-0535		DIODE-SCHOTTKY	28480	1901-0535
A1CR22	1910-0016		DIODE-5E 60V 60MA 1US DO-7	28480	1910-0016
A1CR23	1901-0028		DIODE-PWR RECT 400V 750MA DO-29	04713	SR1358-9
A1CR24	1901-0460	1	DIODE- STATISTOR 15V 150MA DO-7	28480	1901-0460
A1J1	1251-4277	1	CONNECTOR 10-PIN F POST TYPE	28480	1251-4277
A1L1	9100-1633	3	COIL-MLO 68UH 5% Q=55 .155DX.375LG	28426	157682
A1L2	9100-2256	1	COIL-FXD MOLDED RF CHOKE .56UH 10%	28426	107560
A1L3	9100-1633		COIL-MLO 68UH 5% Q=55 .155DX.375LG	28426	157682
A1L4	9100-1633		COIL-MLO 68UH 5% Q=55 .155DX.375LG	28426	157682
A1L5	9100-3139	2	COIL-FXD NON-MOLDED RF CHOKE 75UH 15%	28480	9100-3139
A1L6	9100-3139		COIL-FXD NON-MOLDED RF CHOKE 75UH 15%	28480	9100-3139
A1L7	9100-0346	1	COIL-FXD MOLDED RF CHOKE .05UH 20%	28480	9100-0346
A1P1	1251-2755	1	CONNECTOR 50-PIN F MICRO STRIP	71785	222-22-50-069
A1Q1	1855-0081	1	TRANSISTOR J-FET 2N5245 N-CHAN D-MODE SI	01295	2N5245
A1Q2	1853-0247	1	TRANSISTOR PNP SI PD=200MW FT=1.5GHZ	28480	1853-0247
A1Q3	1855-0356	1	TRANSISTOR J-FET 2N4392 N-CHAN D-MODE	04713	2N4392
A1Q4	1854-0071	5	TRANSISTOR NPN SI PD=300MW FT=200MHZ	28480	1854-0071
A1Q5	1853-0015	4	TRANSISTOR PNP SI PD=200MW FT=500MHZ	28480	1853-0015
A1Q6	1854-0634	1	TRANSISTOR NPN SI PD=1W FT=50MHZ	04713	MPS-001
A1Q7	1854-0071		TRANSISTOR NPN SI PD=300MW FT=200MHZ	28480	1854-0071
A1Q8	1853-0015		TRANSISTOR PNP SI PD=200MW FT=500MHZ	28480	1853-0015
A1Q9	1853-0015		TRANSISTOR PNP SI PD=200MW FT=500MHZ	28480	1853-0015
A1Q10	1853-0015		TRANSISTOR PNP SI PD=200MW FT=500MHZ	28480	1853-0015
A1Q11	1854-0009	4	TRANSISTOR NPN 2N709 SI TO-18 PD=300MW	28480	1854-0009
A1Q12	1854-0009		TRANSISTOR NPN 2N709 SI TO-18 PD=300MW	28480	1854-0009
A1Q13	1854-0009		TRANSISTOR NPN 2N709 SI TO-18 PD=300MW	28480	1854-0009
A1Q14	1854-0071		TRANSISTOR NPN SI PD=300MW FT=200MHZ	28480	1854-0071
A1Q15	1853-0036	2	TRANSISTOR, PNP SI PD=310MW FT=250MHZ	04713	SPS-3612
A1Q16	1853-0036		TRANSISTOR, PNP SI PD=310MW FT=250MHZ	04713	SPS-3612
A1Q17	1854-0071		TRANSISTOR NPN SI PD=300MW FT=200MHZ	28480	1854-0071
A1Q18	1854-0009		TRANSISTOR NPN 2N709 SI TO-18 PD=300MW	28480	1854-0009
A1Q19	1854-0071		TRANSISTOR NPN SI PD=300MW FT=200MHZ	28480	1854-0071
A1R1	2100-3434	1	RESISTOR-VAR CONTROL CC 50K 10% LIN	01121	70M4N048P5030
A1R2	0698-8339	1	RESISTOR 82K 5% .125W CC TC=-466/+875	01121	BB8235
A1R3	0698-7964	2	RESISTOR 100K 5% .125W CC TC=-466/+875	01121	BB1045
A1R4	0698-5176		RESISTOR 510 5% .125W CC TC=-330/+800	01121	BB5115
A1R5	0698-7047	1	RESISTOR 1M 5% .125W CC TC=-600/+1117	01121	BB1055
A1R6	0698-5684	1	RESISTOR 240 5% .125W CC TC=-300/+800	01121	BB2415
A1R7	0683-2015	4	RESISTOR 200 5% .25W FC TC=-400/+600	01121	CB2015
A1R8	0698-5175	6	RESISTOR 360 5% .125W CC TC=-330/+800	01121	BB3615
A1R9	0683-2015		RESISTOR 200 5% .25W FC TC= 400/+600	01121	CB2015
A1R10	0698-7964		RESISTOR 100K 5% .125W CC TC=-466/+875	01121	BB1045
A1R11	0698-5176		RESISTOR 510 5% .125W CC TC=-330/+800	01121	BB5115
A1R12	0698-5180	6	RESISTOR 2K 5% .125W CC TC=-350/+857	01121	BB2025
A1R13	0698-5185	1	RESISTOR 15K 5% .125W CC TC= 466/+857	01121	BB1535
A1R14	0698-5175		RESISTOR 360 5% .125W CC TC=-330/+800	01121	BB3615
A1R15	0698-5180		RESISTOR 2K 5% .125W CC TC= 350/+857	01121	BB2025
A1R16	0698-5180		RESISTOR 2K 5% .125W CC TC= 350/+857	01121	BB2026
A1R17	0698-5180		RESISTOR 2K 5% .125W CC TC= 350/+857	01121	BB2025
A1R18	2100-1734	3	RESISTOR-TRMR 10K 10% C TOP-ADJ 1-TURN	30083	ET50W103
A1R19	0683-1035	12	RESISTOR 10K 5% .25W FC TC=-400/+700	01121	CB1035
A1R20	0683-3025	1	RESISTOR 3K 5% .25W FC TC=-400/+700	01121	CB3025
A1R21	0675-1021		RESISTOR 1K 10% .125W CC TC=-330/+800	01121	BB1071
A1R22	0698-5176		RESISTOR 510 5% .125W CC TC=-330/+800	01121	BB5115
A1R23	0698-5175		RESISTOR 360 5% .125W CC TC=-330/+800	01121	BB3615
A1R24	0698-5176		RESISTOR 510 5% .125W CC TC=-330/+800	01121	BB5115
A1R25	0698-8356	2	RESISTOR 56K 5% .125W CC TC=-466/+875	01121	BB5635
A1R26	0698-5426	4	RESISTOR 10K 10% .125W CC TC=-350/+857	01121	BB1031
A1R27	0698-5160		RESISTOR 2K 5% .125W CC TC=-350/+857	01121	BB2025
A1R28*	0698-5176	4	RESISTOR 510 5% .125W CC TC=-330/+800	01121	BB5115
A1R28*	0675-1021	1	RESISTOR 1K 10% .125W CC TC=-330/+800	01121	BB1071
A1R28*	0698-6241	1	RESISTOR 750 5% .125W CC TC=-330/+800	01121	BB7515
A1R28*	0698-5103		RESISTOR 470 5% .125W CC TC=-330/+800	01121	BB4315
A1R29	0683-1035		RESISTOR 10K 5% .25W FC TC=-400/+700	01121	CB1035
A1R30	0698-5175		RESISTOR 360 5% .125W CC TC= 330/+800	01121	BB3615
A1R31	1810-0171	1	NETWORK RES 6 PIN SIP 15-PIN-SPCG	01130	1810-0171
A1R32	0698-8356		RESISTOR 56K 5% .125W CC TC= 466/+875	01121	BB5635
A1R33	0698-5175		RESISTOR 360 5% .125W CC TC= 330/+800	01121	BB3615
A1R34	0698-5175		RESISTOR 360 5% .125W CC TC= 330/+800	01121	BB3615
A1R35	0683-1045	3	RESISTOR 100K 5% .25W FC TC= 400/+800	01121	CB1045
A1R36	0683-5635	1	RESISTOR 56K 5% .25W FC TC=-400/+800	01121	CB5635
A1R37	0683-3915	1	RESISTOR 390 5% .25W FC TC=-400/+600	01121	CB3915
A1R38	0698-5180		RESISTOR 2K 5% .125W CC TC=-350/+857	01121	BB2025
A1R39	0683-1035		RESISTOR 10K 5% .25W FC TC=-400/+700	01121	CB1035
A1R40	0683-1035		RESISTOR 10K 5% .25W FC TC= 400/+700	01121	CB1035
A1R41	0683-3035	1	RESISTOR 30K 5% .25W FC TC=-400/+800	01121	CB3035
A1R42	0683-6205	1	RESISTOR 62 5% .25W FC TC=-400/+500	01121	CB6205
A1R43	0683-1025	8	RESISTOR 1K 5% .25W FC TC=-400/+600	01121	CB1025
A1R44	2100-2030	1	RESISTOR-TRMR 20K 10% C TOP-ADJ 1-TURN	30083	ET50W203
A1R45	0683-1025		RESISTOR 1K 5% .25W FC TC=-400/+600	01121	CB1025
A1R46	0683-1025		RESISTOR 1K 5% .25W FC TC=-400/+600	01121	CB1025

*FACTORY SELECTED PART

See introduction to this section for ordering information

Table 9E-6-1. Replaceable Parts (Cont'd)

Reference Designation	HP Part Number	Qty	Description	Mfr Code	Mfr Part Number
A1R47	1810-0041	2	NETWORK-RES 9-PIN-SIP .15-PIN-SPCG	28480	1810-0041
A1R48	0683-5115	6	RESISTOR 510 5% .25W FC TC=-400/+600	01121	CB5115
A1R49	0683-1025		RESISTOR 1K 5% .25W FC TC=-400/+600	01121	CB1025
A1R50	0683-1025		RESISTOR 1K 5% .25W FC TC=-400/+600	01121	CB1025
A1R51	0683-1025		RESISTOR 1K 5% .25W FC TC=-400/+600	01121	CB1025
A1R52	1810-0041		NETWORK-RES 9-PIN-SIP .15-PIN-SPCG	28480	1810-0041
A1R53	0683-3015	1	RESISTOR 300 5% .25W FC TC=-400/+600	01121	CB3015
A1R54	0683-2015		RESISTOR 200 5% .25W FC TC=-400/+600	01121	CB2015
A1R55	1810-0139	1	NETWORK-RES 5-PIN-SIP .15-PIN-SPCG	28480	1810-0139
A1R56	0683-5115		RESISTOR 510 5% .25W FC TC=-400/+600	01121	CB5115
A1R57	0683-1035		RESISTOR 10K 5% .25W FC TC=-400/+700	01121	CB1035
A1R58	0683-1035		RESISTOR 10K 5% .25W FC TC=-400/+700	01121	CB1035
A1R59	0683-2245	1	RESISTOR 220K 5% .25W FC TC=-800/+900	01121	CB2245
A1R60	0683-7525	1	RESISTOR 7.5K 5% .25W FC TC=-400/+700	01121	CB7525
A1R61	0683-1045		RESISTOR 100K 5% .25W FC TC=-400/+800	01121	CB1045
A1R62	0683-3345	2	RESISTOR 330K 5% .25W FC TC=-800/+900	01121	CB3345
A1R63	0683-6215	1	RESISTOR 620 5% .25W FC TC=-400/+600	01121	CB6215
A1R64	0683-1035		RESISTOR 10K 5% .25W FC TC=-400/+700	01121	CB1035
A1R65	0683-1025		RESISTOR 1K 5% .25W FC TC=-400/+600	01121	CB1025
A1R66	0683-2015		RESISTOR 200 5% .25W FC TC=-400/+600	01121	CB2015
A1R67	0683-1035		RESISTOR 10K 5% .25W FC TC=-400/+700	01121	CB1035
A1R68	0683-5115		RESISTOR 510 5% .25W FC TC=-400/+600	01121	CB5115
A1R69	0683-5115		RESISTOR 510 5% .25W FC TC=-400/+600	01121	CB5115
A1R70	0683-1035		RESISTOR 10K 5% .25W FC TC=-400/+700	01121	CB1035
A1R71	2100-1738		RESISTOR-TRMR 10K 10% C TOP-ADJ 1-TURN	30983	ET50W103
A1R72	0683-5115		RESISTOR 510 5% .25W FC TC=-400/+600	01121	CB5115
A1R73	0683-5115		RESISTOR 510 5% .25W FC TC=-400/+600	01121	CB5115
A1R74	0683-1035		RESISTOR 10K 5% .25W FC TC=-400/+700	01121	CB1035
A1R75	0683-5105	1	RESISTOR 51 5% .25W FC TC=-400/+500	01121	CB5105
A1R76	0683-5125	3	RESISTOR 5.1K 5% .25W FC TC=-400/+700	01121	CB5125
A1R77	0683-1045		RESISTOR 100K 5% .25W FC TC=-400/+800	01121	CB1045
A1R78	0683-5125		RESISTOR 5.1K 5% .25W FC TC=-400/+700	01121	CB5125
A1R79	2100-1984	1	RESISTOR-TRMR 100 10% C TOP-ADJ 1-TURN	30983	ET50W101
A1R80			NOT ASSIGNED		
A1R81	0683-8235	1	RESISTOR 82K 5% .25W FC TC=-400/+800	01121	CB8235
A1R82	0683-9135	1	RESISTOR 91K 5% .25W FC TC=-400/+800	01121	CB9135
A1R83	0683-2715	1	RESISTOR 270 5% .25W FC TC=-400/+600	01121	CB2715
A1R84	0683-3345		RESISTOR 330K 5% .25W FC TC=-800/+900	01121	CB3345
A1R85	0683-1025		RESISTOR 1K 5% .25W FC TC=-400/+600	01121	CB1025
A1R86	0683-4305	1	RESISTOR 43 5% .25W FC TC=-400/+500	01121	CB4305
A1R87	0683-1035		RESISTOR 10K 5% .25W FC TC=-400/+700	01121	CB1035
A1R88	0683-3615	1	RESISTOR 360 5% .25W FC TC=-400/+600	01121	CB3615
A1R89	0683-6245	1	RESISTOR 620K 5% .25W FC TC=-800/+900	01121	CB6245
A1R90	0683-6225	1	RESISTOR 6.2K 5% .25W FC TC=-400/+700	01121	CB6225
A1R91	0683-5125		RESISTOR 5.1K 5% .25W FC TC=-400/+700	01121	CB5125
A1R92	0683-1035		RESISTOR 10K 5% .25W FC TC=-400/+700	01121	CB1035
A1R93	0683-1035		RESISTOR 10K 5% .25W FC TC=-400/+700	01121	CB1035
A1R94	0683-1215		RESISTOR 120 5% .25W	01121	CB1215
A1S1	3100-3373	1	SWITCH-RTRY 4P4T-NS .562-CTR-SPCG	28480	3100-3373
A1S2	3100-3306	1	SWITCH-RTRY 3P6T-NS .562 IN CTR SPCG	28480	3100-3306
A1TP1	0360-0124	10	TERMINAL-STUD SGL-PIN PRESS-MTG	28480	0360-0124
A1TP2	0360-0124		TERMINAL-STUD SGL-PIN PRESS-MTG	28480	0360-0124
A1TP3	0360-0124		TERMINAL-STUD SGL-PIN PRESS-MTG	28480	0360-0124
A1TP4	0360-0124		TERMINAL-STUD SGL-PIN PRESS-MTG	28480	0360-0124
A1TP5	0360-0124		TERMINAL-STUD SGL-PIN PRESS-MTG	28480	0360-0124
A1TP6	0360-0124		TERMINAL-STUD SGL-PIN PRESS-MTG	28480	0360-0124
A1TP7	0360-0124		TERMINAL-STUD SGL-PIN PRESS-MTG	28480	0360-0124
A1TP8	0360-0124		TERMINAL-STUD SGL-PIN PRESS-MTG	28480	0360-0124
A1TP9	0360-0124		TERMINAL-STUD SGL-PIN PRESS-MTG	28480	0360-0124
A1TP10	0360-0124		TERMINAL-STUD SGL-PIN PRESS-MTG	28480	0360-0124
A1U1	1826-0275	1	IC 78L12AC V RGLTR	04713	MC78L12CP
A1U2	1826-0274	1	IC 78L15AC V RGLTR	04713	MC78L15CP
A1U3	1820-0621	1	IC-DIGITAL SN7438N TTL QUAD 2 NAND	01295	SN7438N
A1U4	1820-0910	1	IC-DIGITAL SN74LS83AN TTL LS BIN	01295	SN74LS83N
A1U5	1820-1166	1	IC-DIGITAL DM85L51N TTL L QUAD	27014	DM85L51N
A1U6	1820-1224	1	IC-DIGITAL MC10216P ECL TPL 2 LINE RCVR	04713	MC10216P
A1U7	1820-0493	2	IC LM 307 OP AMP	27014	LM307N
A1U8	1826-0139	1	IC MC 1458 OP AMP	04713	MC1458P1
A1U9	1820-0681	1	IC-DIGITAL SN74S00N TTL S QUAD 2 NAND	01295	SN74S00N
A1U10	1820-1206	1	IC-DIGITAL SN74LS27N TTL LS TPL 3 NOR	01295	SN74LS27N
A1U11	1820-1443	1	IC-DIGITAL SN74LS293N TTL LS BIN	01295	SN74LS293N
A1U12	1820-0804	1	IC-DIGITAL MC10106P ECL TPL NOR	04713	MC10106P
A1U13	1820-0803	1	IC-DIGITAL MC10105P ECL TPL OR-NOR	04713	MC10105P
A1U14	1820-1383	1	IC-DIGITAL MC10138L ECL BCD	04713	MC10138L
A1U15	1826-0174	2	IC MC 3302 COMPARATOR	28480	1826-0174

See introduction to this section for ordering information

Table 9E-6-1. Replaceable Parts (Cont'd)

Reference Designation	HP Part Number	Qty	Description	Mfr Code	Mfr Part Number
A1U16	1826-0174		IC MC 3302 COMPARATOR	28480	1826-0174
A1U17	1820-0317	1	IC-DIGITAL MC10131P ECL DUAL D-M/S	04713	MC10131P
A1U18	1820-0584	1	IC-DIGITAL DM74L02N TTL L QUAD 2 NOR	27014	DM74L02N
A1U19	1820-1442	3	IC-DIGITAL SN74LS290N TTL LS DECD	01295	SN74LS290N
A1U20	1820-1442		IC-DIGITAL SN74LS290N TTL LS DECD	01295	SN74LS290N
A1U21	1820-1442		IC-DIGITAL SN74LS290N TTL LS DECD	01295	SN74LS290N
A1U22	1820-0630	1	IC-DIGITAL MC4044P TTL	04713	MC4044P
A1U23	1820-0493		IC LM 307 OP AMP	27014	LM307N
A1U24	1820-1307	1	IC-DIGITAL SN74S132N TTL S QUAD 2 NAND	01295	SN74S132N
A1U25	1820-1225	1	IC-DIGITAL MC10231P ECL DUAL D-M/S	04713	MC10231P
A1U26	1820-0712	1	IC: BINARY	28480	1820-0712
A1U27	1826-0147	1	IC 7812C V RGLTR	07263	7812UC
A1U28	1826-0172	1	IC 7805C V RGLTR	07263	7805UC
			A1 MISCELLANEOUS		
	0380-0342	4	STANDOFF-RVT-0N .125LG 6-32THD .250D BR5	28480	0380-0342
	0905-0479	1	WASKET	28480	0905-0479
	05354-00009	5	GROUND SPRING, GOLD	28480	05354-00009
A2	05305-60006	1	1.3 GHZ BOARD ASSEMBLY	28480	05305-60006
A2C1	0160-3878	10	CAPACITOR-FXD 1000PF +-20% 100WVDC CER	28480	0160-3878
A2C2	0160-3878		CAPACITOR-FXD 1000PF +-20% 100WVDC CER	28480	0160-3878
A2C3	0160-3878		CAPACITOR-FXD 1000PF +-20% 100WVDC CER	28480	0160-3878
A2C4	0160-0570	3	CAPACITOR-FXD 220PF +-20% 100WVDC CER	28480	0160-0570
A2C5	0160-3878		CAPACITOR-FXD 1000PF +-20% 100WVDC CER	28480	0160-3878
A2C6	0160-0570		CAPACITOR-FXD 220PF +-20% 100WVDC CER	28480	0160-0570
A2C7	0160-3878		CAPACITOR-FXD 1000PF +-20% 100WVDC CER	28480	0160-3878
A2C8	0160-0570		CAPACITOR-FXD 220PF +-20% 100WVDC CER	28480	0160-0570
A2C9	0160-3878		CAPACITOR-FXD 1000PF +-20% 100WVDC CER	28480	0160-3878
A2C10	0160-3878	1	CAPACITOR-FXD 47PF +-20% 200WVDC CER	28480	0160-3878
A2C11	0160-2599	1	CAPACITOR-FXD 680PF +-10% 200WVDC CER	28480	0160-2599
A2C12	0160-3878		CAPACITOR-FXD 1000PF +-20% 100WVDC CER	28480	0160-3878
A2C13	0160-3878		CAPACITOR-FXD 1000PF +-20% 100WVDC CER	28480	0160-3878
A2C14	0160-3873		CAPACITOR-FXD 4.7PF +-5PF 200WVDC CER	28480	0160-3873
A2C15	0160-3878		CAPACITOR-FXD 1000PF +-20% 100WVDC CER	28480	0160-3878
A2C16	0160-3878		CAPACITOR-FXD 1000PF +-20% 100WVDC CER	28480	0160-3878
A2C17	0160-4415	1	CAPACITOR-FXD .1uF +-5-0% 200WVDC POLYF	28480	0160-4415
A2C18	0160-4249	1	CAPACITOR-FXD 1000PF +-10% 50WVDC CER	16654	38X050S102K (D)
A2CR1	1902-0032	2	DIODE-ZNR 5.49V 5% DO-7 PD=.4W TC=+.009%	04713	SZ 10939-107
A2CR2	1901-0050	2	DIODE-SWITCHING 80V 200MA 2NS DO-7	28480	1901-0050
A2CR3	1902-3171	1	DIODE-ZNR 11V 5% DO-7 PD=.4W TC=+.062%	04713	SZ 10939-194
A2CR4	1901-0050		DIODE-SWITCHING 80V 200MA 2NS DO-7	28480	1901-0050
A2CR5	1901-0639	4	DIODE-PIN 110V	28480	1901-0639
A2CR6	1901-0639		DIODE-PIN 110V	28480	1901-0639
A2CR7	1902-0032		DIODE-ZNR 5.49V 5% DO-7 PD=.4W TC=+.009%	04713	SZ 10939-107
A2CR8	1901-0639		DIODE-PIN 110V	28480	1901-0639
A2CR9	1901-0639		DIODE-PIN 110V	28480	1901-0639
A2CR10	1901-0179		DIODE-SWITCHING 15V 50MA 750PS DO-7	28480	1901-0179
A2CR11	1901-0179		DIODE-SWITCHING 15V 50MA 750PS DO-7	28480	1901-0179
A2CR12	1901-0179		DIODE-SWITCHING 15V 50MA 750PS DO-7	28480	1901-0179
A2CR13	1901-0040		DIODE-SWITCHING 30V 50MA 2NS DO-35	28480	1901-0040
A2L1	9140-0144	2	COIL-FXD MOLDED RF CHOKE 4.7UH 10%	24226	10/471
A2L2	9100-2265	1	COIL-MLD 10UH 10% Q=60 .095DX.25LG	24226	10/102
A2L3	9140-0144		COIL-FXD MOLDED RF CHOKE 4.7UH 10%	24226	10/471
A2P1	1251-4249	10	CONTACT-CONN U/W-POST-TYPE DPSLDR	28480	1251-4249
A2R1	0698-6648	4	R-SISTOR 620 5% .125W CC TC=-330/+800	01121	886215
A2R2	0698-5426		R-SISTOR 10K 10% .125W CC TC=-350/+857	01121	881031
A2R3	0698-6648		R-SISTOR 620 5% .125W CC TC=-330/+800	01121	886215
A2R4	0698-7102	1	R-SISTOR 5.1K 5% .125W CC TC=-350/+857	01121	885125
A2R5	0698-5426		R-SISTOR 10K 10% .125W CC TC=-350/+857	01121	881031
A2R6	0698-6648		R-SISTOR 620 5% .125W CC TC=-330/+800	01121	886215
A2R7	0698-6648		R-SISTOR 620 5% .125W CC TC=-330/+800	01121	886215
A2R8	0683-2265	1	R-SISTOR 22M 5% .25W FC TC=-900/+1200	01121	882265
A2R9	0698-3378	2	R-SISTOR 51 5% .125W CC TC=-270/+540	01121	885105
A2R10	0698-6984	1	R-SISTOR 470 5% .125W CC TC=-330/+800	01121	884715
A2R11	0698-7243	1	R-SISTOR 1.96K 1% .05W F TC=0+/-100	24546	C3-1/8-T0-1961-G
A2R12	0698-5426		R-SISTOR 10K 10% .125W CC TC=-350/+857	01121	881031
A2R13	2100-1738		R-SISTOR-TRMR 10K 10% C TOP-ADJ 1-TURN	30983	ET50W103
A2R14	0698-7288	4	R-SISTOR 147K 1% .05W F TC=0+/-100	24546	C3-1/8-T0-1473-G
A2R15	0698-7288		R-SISTOR 147K 1% .05W F TC=0+/-100	24546	C3-1/8-T0-1473-G
A2R16	0698-7288		R-SISTOR 147K 1% .05W F TC=0+/-100	24546	C3-1/8-T0-1473-G
A2R17	0698-7288		R-SISTOR 147K 1% .05W F TC=0+/-100	24546	C3-1/8-T0-1473-G
A2R18	0698-5174	1	R-SISTOR 200 5% .125W CC TC=-330/+800	01121	882015
A2R19	0698-5177	1	R-SISTOR 820 5% .125W CC TC=-330/+800	01121	888215
A2R20	0693-9105	1	R-SISTOR 91 5% .25W FC TC=-400/+500	01121	889105

See introduction to this section for ordering information

Table 9E-6-1. Replaceable Parts (Cont'd)

Reference Designation	HP Part Number	Qty	Description	Mfr Code	Mfr Part Number
A2R21	0698-4132	1	RESISTOR 62 5% .125W CC TC=-270/+540	01121	886205
A2R22	2100-1986	1	RESISTOR-TRMR 1K 10% C TOP-ADJ 1-TURN	30983	ET50W102
A2R23	0698-3442	1	RESISTOR 237 1% .125W F TC=0+-100	16299	C4-1/8-T0-237R-F
A2R24	0698-3378	1	RESISTOR 51 5% .125W CC TC=-270/+540	01121	885105
A2R25	0811-3468	1	RESISTOR 240 1%	07088	KP50
A2U1	1820-0223	1	IC LM 301A OP AMP	27014	LM301AH
A2U2	5088-7017	1	1.3 GHZ AMPLIFIER	28480	5088-7017
A2U3	1820-1695	1	IC-DIGITAL	28480	1820-1695
A2U4	1820-1694	1	IC-DIGITAL	28480	1820-1694
A2W1	05305-60207	1	1.3 GHZ CABLE	28480	05305-60207
	1250-0821	1	CONNECTOR-RF SMC FEM UNMTD	24931	37P102-1
	1250-0857	1	FERRULE CLAMP:RF CONNECTOR	7706R	30994-4
	05255-2010	1	SLEEVE, COAX	28480	05255-2010
			A2 MISCELLANEOUS		
	05305-00010	3	CLAMP, GRINDING	28480	05305-00010
	05305-20107	1	HOUSING, AMPLIFIER	28480	05305-20107
			CHASSIS PARTS		
F1	2110-0301	2	FUSE .125A 125V FAST-BLO .281X.093	75915	275.125
J1	1250-0186	1	CONNECTOR-RF BNC FEM SGL HOLE FR	90949	31-221-1024
	05305-20104	1	HOLDER, FUSE	28480	05305-20104
	05305-60205	1	CONNECTOR ASSEMBLY, BNC	28480	05305-60205
	05305-60206	1	CONNECTOR ASSEMBLY, SMC	28480	05305-60206
J2	5060-0467	1	MALE PROBE, POWER	28480	5060-0467
			MISCELLANEOUS PARTS		
	0370-1099	3	KNOB-BASE-PTR .5 IN JGK SGI-DECAL	28480	0370-1099
	0510-0076	2	NUT-SHMET 6-32-THD .63-WD STL	78553	C8599-632-24h
	0590-0038	1	NUT-HEX-DBL-CHAM 1/2-32-THD .094-THK	28480	0590-0038
	1460-1311	1	SPRING-LEAF .25-W .58-LG BE CU	28480	1460-1311
	1460-1312	1	SPRING-EXT .25-W .58-LG BE CU	28480	1460-1312
	2950-0043	5	NUT-HEX-DBL-CHAM 3/8-32-THD .094-THK	73743	2X 28200
	9220-1762	1	JUST COVER	28480	9220-1762
	5040-7032	1	FOOT, REAR	28480	5040-7032
	05300-00006	2	CLIP, RFI	28480	05300-00006
	05300-20010	1	CASE	28480	05300-20010
	05300-40003	4	SUPPORT, BOARD	28480	05300-40003
	05300-40004	4	GUIDE, SLIDE	28480	05300-40004
	05301-20005	1	STAND, TILT	28480	05301-20005
	05301-40001	1	FOOT	28480	05301-40001
	05305-00005	1	PANEL, FRONT	28480	05305-00005
	05305-00006	1	PANEL, REAR	28480	05305-00006
	05305-00007	1	BRACKET, FRONT	28480	05305-00007
	05305-00008	1	COVER, HOUSING	28480	05305-00008
	05305-00009	1	SHIELD, AMPLIFIER	28480	05305-00009
	05305-00011	1	SPACKET, 80 MHZ	28480	05305-00011
	05305-20105	1	INSULATOR	28480	05305-20105
	05354-00009	1	GROUND SPRING, GOLD	28480	05354-00009

See introduction to this section for ordering information

Model 5305B
Replaceable Parts

Figure 6-1. Details of Input Connector J1 and Fuse Mounting

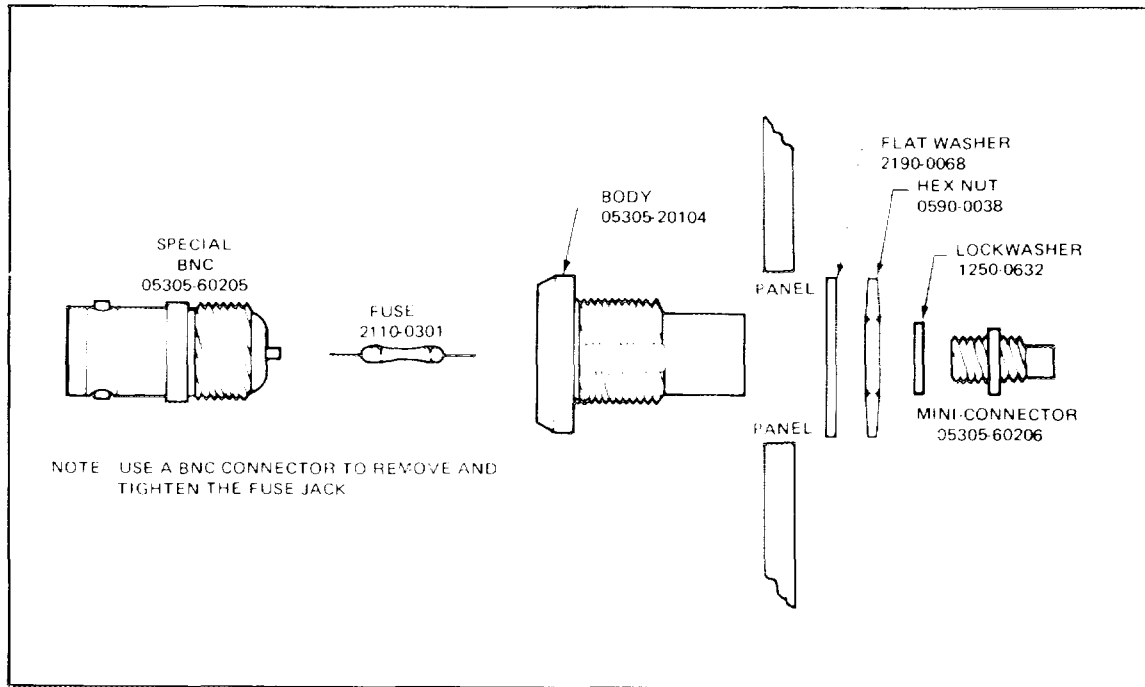

Table 9E-6-2. Manufacturers Code List

Mfr No.	Manufacturer Name	Address	Zip Code
01121	Allen-Bradley Co	Milwaukee, WI	53212
01295	Texas Instr Inc Semicond Cmpnt Div	Dallas, TX	75231
04713	Motorola Semiconductor Products	Phoenix, AZ	85008
07263	Fairchild Semiconductor Div	Mountain View, CA	94040
09023	Cornell-Dubilier Elek Div Fed Pac	Sanford, NC	27330
16299	Corning Gl Wk Elec Cmpnt Div	Raleigh, NC	27604
24226	Gowanda Electronics Corp	Gowanda, NY	14070
24546	Corning Glass Works (Bradford)	Bradford, PA	16701
24931	Speciality Connector Co Inc	Indianapolis, IN	46227
26654	Varadyne Inc	Santa Monica, CA	90403
27014	National Semiconductor Corp	Santa Clara, CA	95051
28480	Hewlett-Packard Co Corporate HQ	Palo Alto, CA	94304
30983	Mepco/Electra Corp	San Diego, CA	92121
56289	Sprague Electric Co	North Adams, MA	01247
71785	TRW Elek Components Cinch Div	Elk Grove Village, IL	60007
72136	Electro Motive Corp Sub IEC	Willimantic, CT	06226
73743	Fischer Special Mfg Co	Cincinnati, OH	45206
75915	Littlefuse Inc	Des Plaines, IL	60016
77068	Bendix Corp Electrodynamics Div	North Hollywood, CA	91605
78553	Tinnerman Products Inc	Cleveland, OH	44129
9D949	Amphenol Sales Div of Bunker-Ramo	Hazelwood, MO	63042

SECTION IX E
5305B 1300 MHz COUNTER

SUBSECTION VII
MANUAL CHANGES

9E-7-1. MANUAL CHANGES

9E-7-2. Section IX E applies directly to model 5305B 1300 MHz Counters having Serial Prefix number 1616A.

9E-7-3. Newer Instruments

9E-7-4. As changes are made, newer instruments may have serial number prefixes not listed in Section IX E. The manuals for these instruments will be supplied with "Manual Changes" sheets containing the required information; replace the affected pages with the replacement "manual changes" pages. Contact the nearest Hewlett-Packard Sales and Service Office for information if these pages are missing.

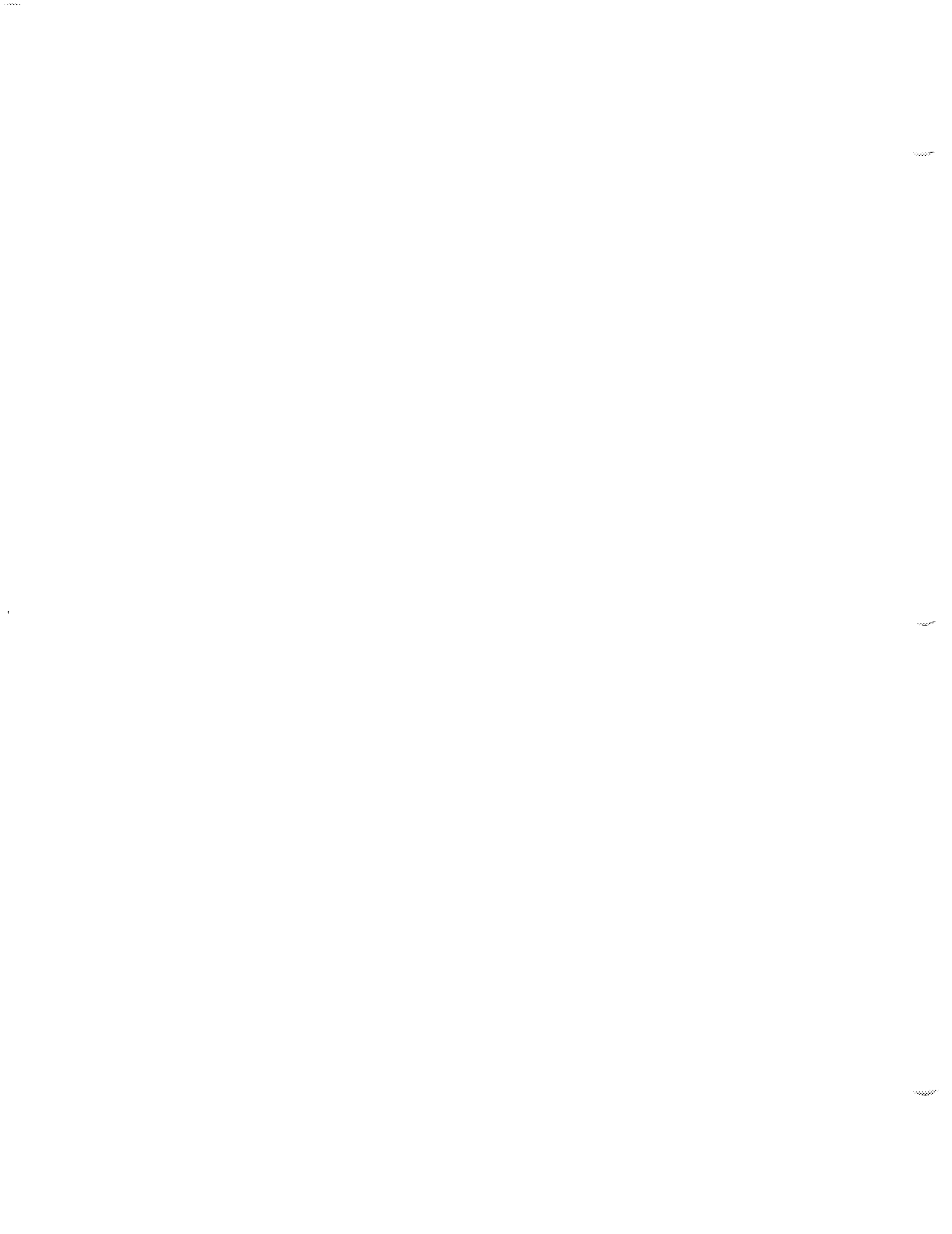

SECTION IX E
5305B 1100 MHz COUNTER

SUBSECTION VIII
CIRCUIT DIAGRAMS

9E-8-1. INTRODUCTION

9E-8-2. This subsection of the manual contains the following information:

- a. A signal list that gives the signal name and connector pin number of each signal that interconnects with the mainframe (see Table 9E-8-1).
- b. Signal waveforms at key points in the input amplifiers and clock circuits.

c. Component location views of the printed-circuit boards.

d. Schematic diagrams of the counter.

9E-8-3. Use the information in this subsection in conjunction with the information provided in Subsection V, Maintenance, while troubleshooting the counter.

Table 9E-8-1. Counter Signal List

PIN NO.	SIGNAL NAME	DESCRIPTION
1	+5 V	Circuit operating voltages
2	-5 V	
3	-17V	
4	COMMON RETURN	Common power and signal return line.
5	F1	Signal to be counted in the mainframe.
6	"9"	Goes low when the mainframe counter reaches 9% full-scale. Tied to pin 14.
7	F2	Time Base Clock 10 MHz or 10 MHz ÷ 16.
8	INHIBIT	High during the measurement cycle, low during the display cycle.
9	OPEN	Low signal forces the main gate flip-flop in the mainframe to the open position.
10	CLOSE	Low signal forces the main gate flip-flop in the mainframe to the closed position.
11	LOG	Logarithmic pulse train from time base triggers main gate flip-flop on rising edge.
12	NC	
13	EXPONENT	Inverted log pulses while main gate in mainframe is open indicates number of auto-ranging steps.
14	OVERFLOW	Low signal enables overflow and storage.
15	RESET	High signal resets all registers.
16	CLOCK	10 MHz reference signal from mainframe crystal oscillator.
17	MAX TIME	Low signal enables closing of the main gate in the mainframe on next log pulse. Rising edge initiates display cycle.
18	TIME BASE OUTPUT	Output from the time base decade that is selected by the time base select code on pins 22, 23, and 24.

Table 9E-8-1. Counter Signal List (Continued)

PIN NO.	SIGNAL NAME	DESCRIPTION
19	$\overline{\text{PRINT}}$	Low signal provides print command to rear panel connector on mainframe.
20	$\overline{\text{TRANSFER}}$	Low signal transfers data to display. High signal stores data.
21	1 MHz TIME BASE INPUT	Input direct from plug-on bypasses control circuit.
22	TIME BASE SELECT A	Time base select code A, B, and C determines the time base frequency at the time base output, pin 18.
23	TIME BASE SELECT B	
24	TIME BASE SELECT C	
25	+22 V	Full wave rectified voltage from the power transformer secondary. Provides power to charge the battery pack. If no battery pack is used, pin 25 is connected via the plug-on to pin 50 (DC-IN).
26	+17 V	
27	$\overline{\text{Hz}}$	Pins 27 through 31 provide the drive to the annunciator lights on the front panel. A low signal lights the corresponding indicator.
28	$\overline{\text{M}}$	
29	S	
30	$\overline{\text{K}}$	
31	$\overline{\text{u}}$	
32	$\overline{\text{MAN RES}}$	Low signal from front panel pushbutton switch or rear panel input clears the system to zero.
33	$\overline{\text{DP1}}$	Low signal activates decimal point 1.
34	$\overline{\text{DP2}}$	Low signal activates decimal point 2.
35	NC	
36	DIGIT ADDRESS X	Digit address code X, Y, Z from the display scanner indicates which data digit is being displayed.
37	DIGIT SELECT X	
38	DIGIT ADDRESS Y	
39	DIGIT SELECT Y	Digit select code X, Y, Z is the code that selects the mainframe counter digit that is to be displayed. If the mainframe counter is displayed directly, the corresponding lines of the digit address code and the digit select code are connected together.
40	DIGIT ADDRESS Z	
41	DIGIT SELECT Z	
42	DATA "D"	The data code A, B, C, D represents the digit to be displayed in binary coded decimal form. Data lines can carry the mainframe counter information to the plug-on as well as to the display or can bypass the counter and bring plug-on data to the display.
43	DATA "C"	
44	DATA "B"	
45	DATA "A"	
46	$\overline{\text{DP3}}$	Low signal activates decimal point 3.
47	$\overline{\text{DP4}}$	Low signal activates decimal point 4.
48	$\overline{\text{DP5}}$	Low signal activates decimal point 5.
49	COMMON RETURN	Common power and signal return line.
50	DC IN	DC Power to power supply from battery pack or from 22 volt input power at pin 25.

Part of Figure 8-1. Channel B and Frequency Multiplier Circuits, Schematic Diagram

Input Signal: 9 kHz at 1V rms
Oscilloscope: HP 180A/1801A/1821A with 10:1 probe

Oscilloscope Settings: DISPLAY: ALT
(Unless otherwise stated) POLARITY: +
Coupling: A.C.
TIME/DIV: .1 ms

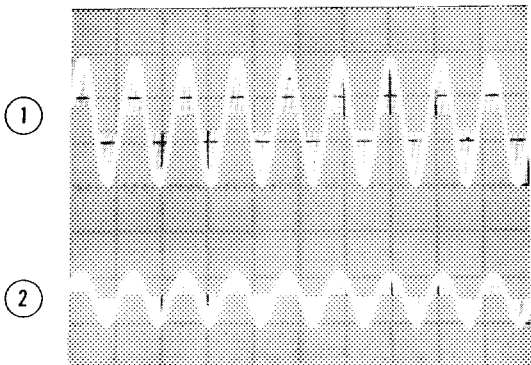

1. .1V/DIV
2. .01V/DIV

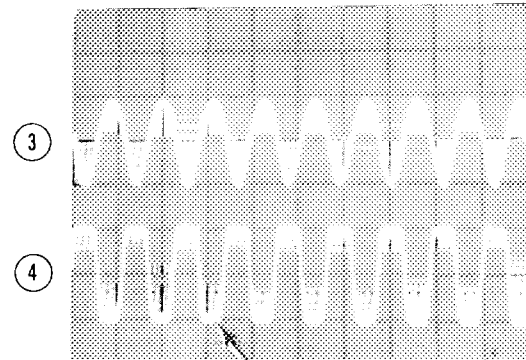

3. .02V/DIV
4. .05V/DIV

Appears as a sine wave
with small input signal

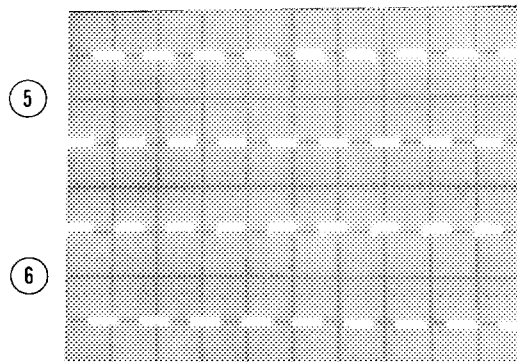

5. .05V/DIV
6. .2V/DIV

Part of Figure 8-1. Channel B and Frequency Multiplier Circuits, Schematic Diagram (Cont'd)



NOTES

1. REFERENCE DESIGNATIONS WITHIN THIS ASSEMBLY ARE ABBREVIATED. ADD ASSEMBLY NUMBER TO ABBREVIATION FOR COMPLETE DESCRIPTION.
2. UNLESS OTHERWISE INDICATED:
RESISTANCE IN OHMS;
CAPACITANCE IN PICO FARADS
INDUCTANCE IN MICROHENRIES
3. +17VB .5VA AND +5VB IS SWITCHED FROM A1S1

A1 TABLE OF ACTIVE ELEMENTS

Ref. Desig.	HP Part No.	Mfr or Industry Part No.
CR1, 10, 16, 20,22	1910-0016	
CR2, 4, 5, 7	1901-0179	
CR3	1902-0025	SZ 10939-182
CR6, 8, 15, 16, 17	1901-0040	
18, 19	1901-0040	
CR9, 11, 12, 13, 21	1901-0535	
CR14, 23	1901-0028	SR 1358-9
CR24	1901-0460	
Q1	1855-0081	2N5245
Q2	1853-0247	
Q3	1855-0386	2N4392
Q4, 7, 14, 17, 19	1854-0071	
Q5, 8, 9, 10	1853-0015	
Q6	1854-0634	MPS U01
Q11, 12, 13, 18	1854-0009	
Q15, Q16	1853-0036	SPS-3612
U1	1826-0275	MC78L12CP
U2	1826-0274	MC78L15CP
U3	1820-0621	SN7438N
U4	1820-0910	SN74LS83N
U5	1820-1166	DM85L51N
U6	1820-1224	MC10216P
U7, 23	1820-0493	LM307N
U8	1826-0139	MC1458P1
U9	1820-0681	SN74S00N
U10	1820-1206	SN74LS27N
U11	1820-1443	SN74LS293N
U12	1820-0804	MC10106P
U13	1820-0803	MC10105P
U14	1820-1383	MC10138L
U15, 16	1826-0174	
U17	1820-0817	MC10131P
U18	1820-0584	DM74L02N
U19, 20, 21	1820-1442	SN74LS290N
U22	1820-0630	MC4044P
U24	1820-1307	SN74S132N
U25	1820-1225	MC10231P
U26	1820-0712	
U27	1820-0147	7812UC
U28	1826-0122	7805UC

Part of Figure 8-2. Channel A and Logic Board Circuits, Schematic Diagram

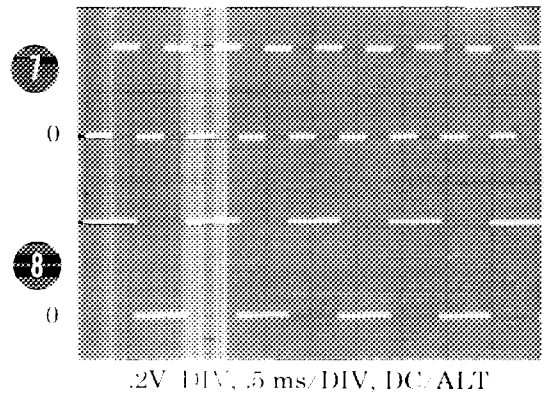
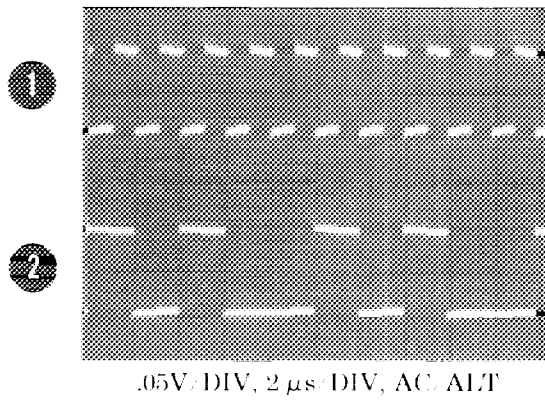

Note: Waveforms 1 thru 10 taken with 1 MHz input and RESOLUTION switch set to .1 Hz. Waveforms 11 thru 15 taken with 100 MHz input.

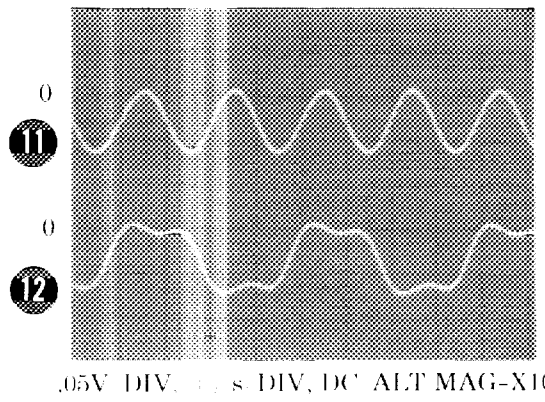
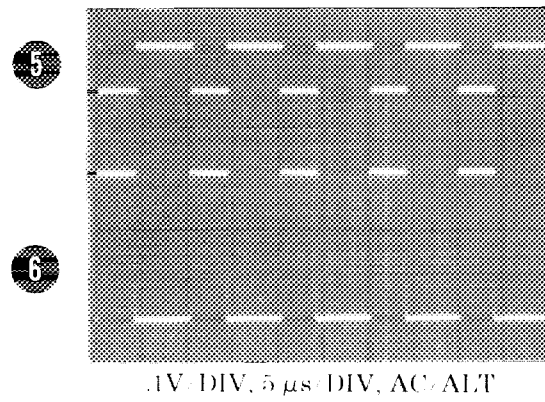
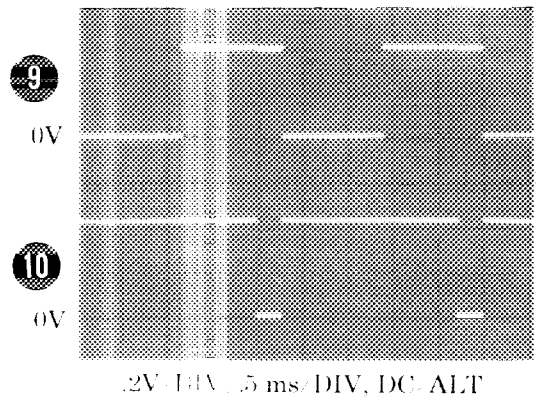
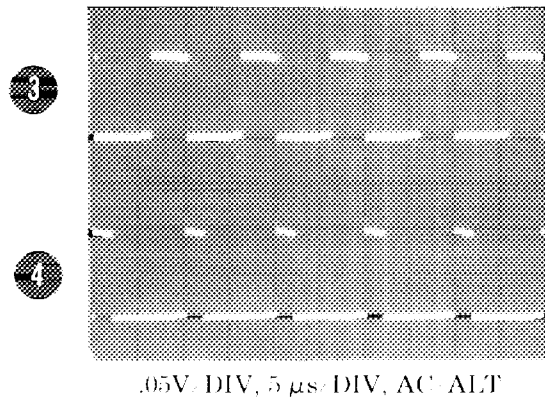

Part of Figure 8-2. Channel A and Logic Board Circuits, Schematic Diagram (Cont'd)

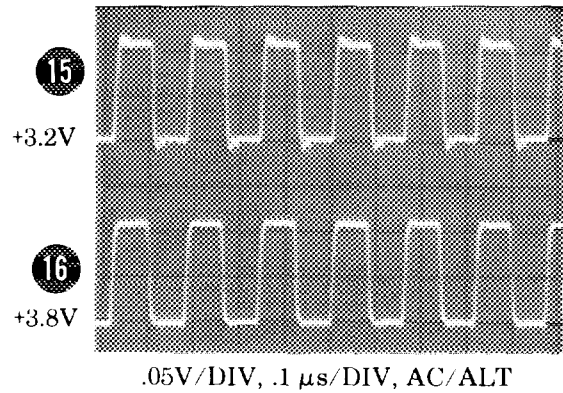
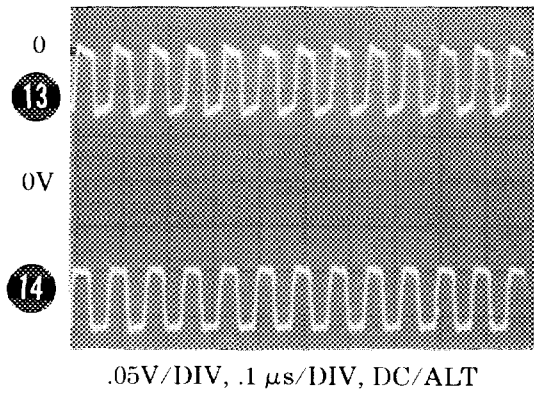

**A2 1.3 GHz AMPLIFIER
DC VOLTAGE MEASUREMENTS WITH NO INPUT SIGNAL**

ATTN: MIN

- | | | |
|----|--------------|-------|
| 1. | CR5 Anode | 10.5V |
| 2. | CR5 Cathode | 10.2V |
| 3. | CR6 Anode | 12V |
| 4. | CR6 Anode | 11.2V |
| 5. | CR8 Cathode | 10.5V |
| 6. | CR9 Anode | 10.2V |
| 7. | CR10 Cathode | .8V |
| 8. | CR12 Cathode | 8V |
| 9. | CR11 Cathode | 8V |

RANGE: 1300 MHz

ATTN: MAX

- | | | |
|----|--------------|------|
| 1. | CR5 Anode | 3.1V |
| 2. | CR5 Cathode | 2.5V |
| 3. | CR6 Anode | 0V |
| 4. | CR6 Cathode | 0V |
| 5. | CR8 Cathode | 1.4V |
| 6. | CR9 Anode | 2.0V |
| 7. | CR10 Cathode | .82V |
| 8. | CR12 Cathode | 8.0V |
| 9. | CR11 Cathode | 8.0V |

NOTE

These voltages will vary depending on the position of R13.

Part of Figure 8-2. Channel A and Logic Board Circuits, Schematic Diagram (Cont'd)

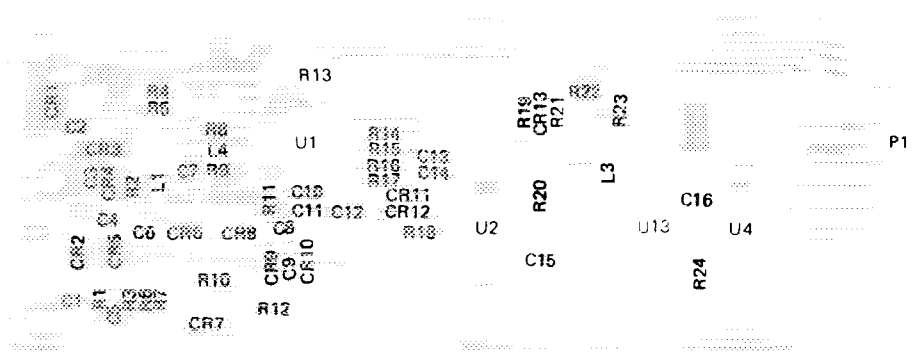

A2 TABLE OF ACTIVE ELEMENTS		
Ref. Desig.	HP Part No.	Mfr or Industry Part No.
CR1, 7	1902-0032	SZ 10939 107
CR2, 4	1901-0050	
CR3	1902-3171	SZ 10939 194
CR5, 6, 8, 9	1901-0639	
CR10, 11, 12	1901-0179	
CR13	1901-0040	
U1	1820-0223	LM301AH
U2	5088-7017	
U3	1820-1695	
U4	1820-1694	

REFERENCE DESIGNATIONS	
A1	A2
C1 50	C1-18
CR1-24	CR1-13
J1	L1 3
L1 7	P1
P1	R1 25
Q1 19	U1 4
R1 94	W1
S1-2	
TP1-10	
U1-28	

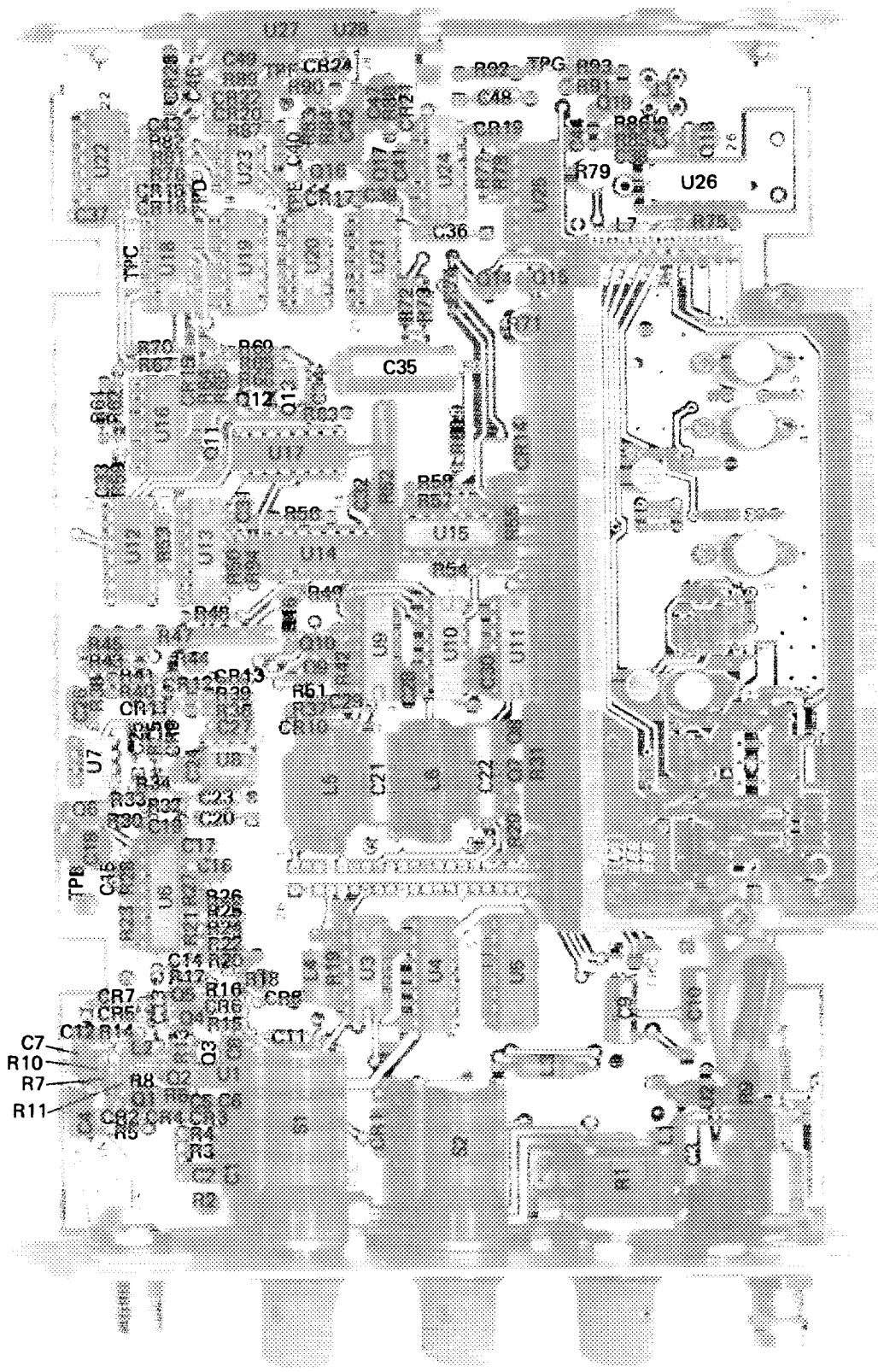

SALES & SERVICE OFFICES

AFRICA, ASIA, AUSTRALIA

ANGOLA

Electra
Empresa Técnica de Equipamentos
Electronics S.A. R.L.
H. Barbosa Rodrigues 474 DT
Caxa Postal 5487
Luanda
Tel: 355116
Cable: TELEFOTRA Luanda

AUSTRALIA

Hewlett Packard Australia Pty. Ltd.
31-41 Joseph Street
Blackburn Victoria 3130
P.O. Box 35
Doncaster East Victoria 3109
Tel: 496351
Telex: 31-024
Cable: HEWPARD Melbourne
Hewlett Packard Australia Pty. Ltd.
31 Bridge Street
Pymble
New South Wales, 2073
Tel: 4436566
Telex: 21561
Cable: HEWPARD Sydney
Hewlett Packard Australia Pty. Ltd.
153 Greenhill Road
Parkmore S.A. 5063
Tel: 2725911
Telex: 82536
Cable: HEWPARD Adelaide
Hewlett Packard Australia Pty. Ltd.
141 Shirling Highway
Nedlands W.A. 6004
Tel: 466345
Telex: 93659
Cable: HEWPARD Perth
Hewlett Packard Australia Pty. Ltd.
*21 Wollongong Street
Fyshwick A.C.T. 2609
Tel: 674244
Telex: 62650
Cable: HEWPARD Canberra
Hewlett Packard Australia Pty. Ltd.
7th Floor
Teachers Union Building
495-499 Boundary Street
Spring Hill Queensland 4000
Tel: 2951544
Cable: HEWPARD Brisbane
Hewlett Packard Australia Pty. Ltd.
The General Electric Co. of Bangladesh Ltd.
Magnum House 72
Tajulisha Commercial Area
Motijheel, Dhaka 2
Tel: 252415, 252419
Telex: 734
Cable: GECDAC Dhaka

ETHIOPIA

Abdiria Abdoumaki
P.O. Box 2635
Addis Ababa
H. Barboza Rodrigues 474 DT
Caxa Postal 5487
Luanda
Tel: 355116
Cable: TELEFOTRA Luanda

GUAM

Medical Only
Guam Medical Supply Inc.
Suite C, Airport Plaza
P.O. Box 6947
Tamuning 96911
Tel: 646-4513
Cable: EARMED Guam

HONG KONG

Schmidt & Co. (Hong Kong) Ltd
Wing On Centre, 28th Floor
Cantonment Road, C
Hong Kong
Tel: 5-455644
Telex: 74766 SCHMC HK
Cable: HEWPARD

INDIA

Blue Star Ltd
256 Koda Mookkam High Road
Prathapgarh
Bomby 400 020
Tel: 29 50 21
Cable: BLUEFROST
Blue Star Ltd
Sahas
414/2 Vir Savakar Marg
Prathapgarh
Bomby 400 025
Tel: 45 76 87
Cable: BLUEFROST
Blue Star Ltd
23 Jini Jamboti
Surabaya
Tel: 42057
Cable: BLUESTAR
Blue Star Ltd
Shaydop
Atmopodod 380 014
Tel: 42880
Cable: BLUEFROST
Blue Star Ltd
7-ware Street
P.O. Box 505
Calcutta 700 001
Tel: 23 01 31
Cable: BLUESTAR
Blue Star Ltd
Bhandari House
7th & 8th Floor
91 Nandu Place
Wing On Centre, 28th Floor
Cantonment Road, C
Tel: 634770 & 635156
Tel: 031-2463
Cable: BLUESTAR

INDONESIA

BETA Indonesia P.T.
P.O. Box 495 Jm
Jlr Abdul Muis 62
Jakarta
Tel: 3-20255, 3-10866
Telex: 48-28 HENSHI A
Cable: BERCAL
BETA Indonesia P.T.
P.O. Box 174 Nhy
23 Jini Jamboti
Surabaya
Tel: 42057
Cable: BLUESTAR
Blue Star Ltd
Shaydop
Atmopodod 380 014
Tel: 42880
Cable: BLUEFROST
Blue Star Ltd
7-ware Street
P.O. Box 505
Calcutta 700 001
Tel: 23 01 31
Cable: BLUESTAR
Blue Star Ltd
Bhandari House
7th & 8th Floor
91 Nandu Place
Wing On Centre, 28th Floor
Cantonment Road, C
Tel: 634770 & 635156
Tel: 031-2463
Cable: BLUESTAR

INDONESIA

Blue Star Ltd
Shaydop
Atmopodod 380 014
Tel: 42880
Cable: BLUEFROST
Blue Star Ltd
7-ware Street
P.O. Box 505
Calcutta 700 001
Tel: 23 01 31
Cable: BLUESTAR
Blue Star Ltd
Bhandari House
7th & 8th Floor
91 Nandu Place
Wing On Centre, 28th Floor
Cantonment Road, C
Tel: 634770 & 635156
Tel: 031-2463
Cable: BLUESTAR

INDONESIA

Blue Star Ltd
Shaydop
Atmopodod 380 014
Tel: 42880
Cable: BLUEFROST
Blue Star Ltd
7-ware Street
P.O. Box 505
Calcutta 700 001
Tel: 23 01 31
Cable: BLUESTAR
Blue Star Ltd
Bhandari House
7th & 8th Floor
91 Nandu Place
Wing On Centre, 28th Floor
Cantonment Road, C
Tel: 634770 & 635156
Tel: 031-2463
Cable: BLUESTAR

INDONESIA

Blue Star Ltd
Shaydop
Atmopodod 380 014
Tel: 42880
Cable: BLUEFROST
Blue Star Ltd
7-ware Street
P.O. Box 505
Calcutta 700 001
Tel: 23 01 31
Cable: BLUESTAR
Blue Star Ltd
Bhandari House
7th & 8th Floor
91 Nandu Place
Wing On Centre, 28th Floor
Cantonment Road, C
Tel: 634770 & 635156
Tel: 031-2463
Cable: BLUESTAR

INDONESIA

Blue Star Ltd
Shaydop
Atmopodod 380 014
Tel: 42880
Cable: BLUEFROST
Blue Star Ltd
7-ware Street
P.O. Box 505
Calcutta 700 001
Tel: 23 01 31
Cable: BLUESTAR
Blue Star Ltd
Bhandari House
7th & 8th Floor
91 Nandu Place
Wing On Centre, 28th Floor
Cantonment Road, C
Tel: 634770 & 635156
Tel: 031-2463
Cable: BLUESTAR

INDONESIA

Blue Star Ltd
Shaydop
Atmopodod 380 014
Tel: 42880
Cable: BLUEFROST
Blue Star Ltd
7-ware Street
P.O. Box 505
Calcutta 700 001
Tel: 23 01 31
Cable: BLUESTAR
Blue Star Ltd
Bhandari House
7th & 8th Floor
91 Nandu Place
Wing On Centre, 28th Floor
Cantonment Road, C
Tel: 634770 & 635156
Tel: 031-2463
Cable: BLUESTAR

INDONESIA

Blue Star Ltd
Shaydop
Atmopodod 380 014
Tel: 42880
Cable: BLUEFROST
Blue Star Ltd
7-ware Street
P.O. Box 505
Calcutta 700 001
Tel: 23 01 31
Cable: BLUESTAR
Blue Star Ltd
Bhandari House
7th & 8th Floor
91 Nandu Place
Wing On Centre, 28th Floor
Cantonment Road, C
Tel: 634770 & 635156
Tel: 031-2463
Cable: BLUESTAR

INDONESIA

Blue Star Ltd
Shaydop
Atmopodod 380 014
Tel: 42880
Cable: BLUEFROST
Blue Star Ltd
7-ware Street
P.O. Box 505
Calcutta 700 001
Tel: 23 01 31
Cable: BLUESTAR
Blue Star Ltd
Bhandari House
7th & 8th Floor
91 Nandu Place
Wing On Centre, 28th Floor
Cantonment Road, C
Tel: 634770 & 635156
Tel: 031-2463
Cable: BLUESTAR

INDONESIA

Blue Star Ltd
Shaydop
Atmopodod 380 014
Tel: 42880
Cable: BLUEFROST
Blue Star Ltd
7-ware Street
P.O. Box 505
Calcutta 700 001
Tel: 23 01 31
Cable: BLUESTAR
Blue Star Ltd
Bhandari House
7th & 8th Floor
91 Nandu Place
Wing On Centre, 28th Floor
Cantonment Road, C
Tel: 634770 & 635156
Tel: 031-2463
Cable: BLUESTAR

Blue Star Ltd

Blue Star House
1174 Magrath Road
Bangalore 560 025
Tel: 59668
Telex: 741 439
Cable: BLUESTAR
Blue Star Ltd
Mekashi Mandiram
c/o 1578 Mahatma Gandhi Rd
Cochin 682 016
Tel: 32766 2161 32782
Telex: 0485 514
Cable: BLUESTAR
Blue Star Ltd
1.1.117.1
Saripati Dev. Head
Secunderabad 500 063
Tel: 70126 70127
Cable: BLUESTAR
Blue Star Ltd
1.1.117.1
Saripati Dev. Head
Secunderabad 500 063
Tel: 70126 70127
Cable: BLUESTAR
Blue Star Ltd
1.1.117.1
Saripati Dev. Head
Secunderabad 500 063
Tel: 70126 70127
Cable: BLUESTAR

Blue Star Ltd

Blue Star House
1174 Magrath Road
Bangalore 560 025
Tel: 59668
Telex: 741 439
Cable: BLUESTAR
Blue Star Ltd
Mekashi Mandiram
c/o 1578 Mahatma Gandhi Rd
Cochin 682 016
Tel: 32766 2161 32782
Telex: 0485 514
Cable: BLUESTAR
Blue Star Ltd
1.1.117.1
Saripati Dev. Head
Secunderabad 500 063
Tel: 70126 70127
Cable: BLUESTAR
Blue Star Ltd
1.1.117.1
Saripati Dev. Head
Secunderabad 500 063
Tel: 70126 70127
Cable: BLUESTAR

Blue Star Ltd

Blue Star House
1174 Magrath Road
Bangalore 560 025
Tel: 59668
Telex: 741 439
Cable: BLUESTAR
Blue Star Ltd
Mekashi Mandiram
c/o 1578 Mahatma Gandhi Rd
Cochin 682 016
Tel: 32766 2161 32782
Telex: 0485 514
Cable: BLUESTAR
Blue Star Ltd
1.1.117.1
Saripati Dev. Head
Secunderabad 500 063
Tel: 70126 70127
Cable: BLUESTAR
Blue Star Ltd
1.1.117.1
Saripati Dev. Head
Secunderabad 500 063
Tel: 70126 70127
Cable: BLUESTAR

Blue Star Ltd

Blue Star House
1174 Magrath Road
Bangalore 560 025
Tel: 59668
Telex: 741 439
Cable: BLUESTAR
Blue Star Ltd
Mekashi Mandiram
c/o 1578 Mahatma Gandhi Rd
Cochin 682 016
Tel: 32766 2161 32782
Telex: 0485 514
Cable: BLUESTAR
Blue Star Ltd
1.1.117.1
Saripati Dev. Head
Secunderabad 500 063
Tel: 70126 70127
Cable: BLUESTAR
Blue Star Ltd
1.1.117.1
Saripati Dev. Head
Secunderabad 500 063
Tel: 70126 70127
Cable: BLUESTAR

Blue Star Ltd

Blue Star House
1174 Magrath Road
Bangalore 560 025
Tel: 59668
Telex: 741 439
Cable: BLUESTAR
Blue Star Ltd
Mekashi Mandiram
c/o 1578 Mahatma Gandhi Rd
Cochin 682 016
Tel: 32766 2161 32782
Telex: 0485 514
Cable: BLUESTAR
Blue Star Ltd
1.1.117.1
Saripati Dev. Head
Secunderabad 500 063
Tel: 70126 70127
Cable: BLUESTAR
Blue Star Ltd
1.1.117.1
Saripati Dev. Head
Secunderabad 500 063
Tel: 70126 70127
Cable: BLUESTAR

Blue Star Ltd

Blue Star House
1174 Magrath Road
Bangalore 560 025
Tel: 59668
Telex: 741 439
Cable: BLUESTAR
Blue Star Ltd
Mekashi Mandiram
c/o 1578 Mahatma Gandhi Rd
Cochin 682 016
Tel: 32766 2161 32782
Telex: 0485 514
Cable: BLUESTAR
Blue Star Ltd
1.1.117.1
Saripati Dev. Head
Secunderabad 500 063
Tel: 70126 70127
Cable: BLUESTAR
Blue Star Ltd
1.1.117.1
Saripati Dev. Head
Secunderabad 500 063
Tel: 70126 70127
Cable: BLUESTAR

Blue Star Ltd

Blue Star House
1174 Magrath Road
Bangalore 560 025
Tel: 59668
Telex: 741 439
Cable: BLUESTAR
Blue Star Ltd
Mekashi Mandiram
c/o 1578 Mahatma Gandhi Rd
Cochin 682 016
Tel: 32766 2161 32782
Telex: 0485 514
Cable: BLUESTAR
Blue Star Ltd
1.1.117.1
Saripati Dev. Head
Secunderabad 500 063
Tel: 70126 70127
Cable: BLUESTAR
Blue Star Ltd
1.1.117.1
Saripati Dev. Head
Secunderabad 500 063
Tel: 70126 70127
Cable: BLUESTAR

Blue Star Ltd

Blue Star House
1174 Magrath Road
Bangalore 560 025
Tel: 59668
Telex: 741 439
Cable: BLUESTAR
Blue Star Ltd
Mekashi Mandiram
c/o 1578 Mahatma Gandhi Rd
Cochin 682 016
Tel: 32766 2161 32782
Telex: 0485 514
Cable: BLUESTAR
Blue Star Ltd
1.1.117.1
Saripati Dev. Head
Secunderabad 500 063
Tel: 70126 70127
Cable: BLUESTAR
Blue Star Ltd
1.1.117.1
Saripati Dev. Head
Secunderabad 500 063
Tel: 70126 70127
Cable: BLUESTAR

Blue Star Ltd

Blue Star House
1174 Magrath Road
Bangalore 560 025
Tel: 59668
Telex: 741 439
Cable: BLUESTAR
Blue Star Ltd
Mekashi Mandiram
c/o 1578 Mahatma Gandhi Rd
Cochin 682 016
Tel: 32766 2161 32782
Telex: 0485 514
Cable: BLUESTAR
Blue Star Ltd
1.1.117.1
Saripati Dev. Head
Secunderabad 500 063
Tel: 70126 70127
Cable: BLUESTAR
Blue Star Ltd
1.1.117.1
Saripati Dev. Head
Secunderabad 500 063
Tel: 70126 70127
Cable: BLUESTAR

Blue Star Ltd

Blue Star House
1174 Magrath Road
Bangalore 560 025
Tel: 59668
Telex: 741 439
Cable: BLUESTAR
Blue Star Ltd
Mekashi Mandiram
c/o 1578 Mahatma Gandhi Rd
Cochin 682 016
Tel: 32766 2161 32782
Telex: 0485 514
Cable: BLUESTAR
Blue Star Ltd
1.1.117.1
Saripati Dev. Head
Secunderabad 500 063
Tel: 70126 70127
Cable: BLUESTAR
Blue Star Ltd
1.1.117.1
Saripati Dev. Head
Secunderabad 500 063
Tel: 70126 70127
Cable: BLUESTAR

Blue Star Ltd

Blue Star House
1174 Magrath Road
Bangalore 560 025
Tel: 59668
Telex: 741 439
Cable: BLUESTAR
Blue Star Ltd
Mekashi Mandiram
c/o 1578 Mahatma Gandhi Rd
Cochin 682 016
Tel: 32766 2161 32782
Telex: 0485 514
Cable: BLUESTAR
Blue Star Ltd
1.1.117.1
Saripati Dev. Head
Secunderabad 500 063
Tel: 70126 70127
Cable: BLUESTAR
Blue Star Ltd
1.1.117.1
Saripati Dev. Head
Secunderabad 500 063
Tel: 70126 70127
Cable: BLUESTAR

Blue Star Ltd

Blue Star House
1174 Magrath Road
Bangalore 560 025
Tel: 59668
Telex: 741 439
Cable: BLUESTAR
Blue Star Ltd
Mekashi Mandiram
c/o 1578 Mahatma Gandhi Rd
Cochin 682 016
Tel: 32766 2161 32782
Telex: 0485 514
Cable: BLUESTAR
Blue Star Ltd
1.1.117.1
Saripati Dev. Head
Secunderabad 500 063
Tel: 70126 70127
Cable: BLUESTAR
Blue Star Ltd
1.1.117.1
Saripati Dev. Head
Secunderabad 500 063
Tel: 70126 70127
Cable: BLUESTAR

Blue Star Ltd

Blue Star House
1174 Magrath Road
Bangalore 560 025
Tel: 59668
Telex: 741 439
Cable: BLUESTAR
Blue Star Ltd
Mekashi Mandiram
c/o 1578 Mahatma Gandhi Rd
Cochin 682 016
Tel: 32766 2161 32782
Telex: 0485 514
Cable: BLUESTAR
Blue Star Ltd
1.1.117.1
Saripati Dev. Head
Secunderabad 500 063
Tel: 70126 70127
Cable: BLUESTAR
Blue Star Ltd
1.1.117.1
Saripati Dev. Head
Secunderabad 500 063
Tel: 70126 70127
Cable: BLUESTAR

Blue Star Ltd

Blue Star House
1174 Magrath Road
Bangalore 560 025
Tel: 59668
Telex: 741 439
Cable: BLUESTAR
Blue Star Ltd
Mekashi Mandiram
c/o 1578 Mahatma Gandhi Rd
Cochin 682 016
Tel: 32766 2161 32782
Telex: 0485 514
Cable: BLUESTAR
Blue Star Ltd
1.1.117.1
Saripati Dev. Head
Secunderabad 500 063
Tel: 70126 70127
Cable: BLUESTAR
Blue Star Ltd
1.1.117.1
Saripati Dev. Head
Secunderabad 500 063
Tel: 70126 70127
Cable: BLUESTAR

Blue Star Ltd

Blue Star House
1174 Magrath Road
Bangalore 560 025
Tel: 59668
Telex: 741 439
Cable: BLUESTAR
Blue Star Ltd
Mekashi Mandiram
c/o 1578 Mahatma Gandhi Rd
Cochin 682 016
Tel: 32766 2161 32782
Telex: 0485 514
Cable: BLUESTAR
Blue Star Ltd
1.1.117.1
Saripati Dev. Head
Secunderabad 500 063
Tel: 70126 70127
Cable: BLUESTAR
Blue Star Ltd
1.1.117.1
Saripati Dev. Head
Secunderabad 500 063
Tel: 70126 70127
Cable: BLUESTAR

Kyokawa Hewlett Packard Ltd

Nakano Building
24 Kam Satagami-cho
Naka-murakami, Nagoya 450
Tel: 052-571-5171
Kyokawa Hewlett Packard Ltd
Tengacha Building
2-24-1, Tsuyasaka-cho
Kanagawa-ku
Yokohama 221
Tel: 045-312-252
Telex: 382 3704 YHP YOK
Kyokawa Hewlett Packard Ltd
Mio Mitsui Building
105, 1-chome, San-nomaru
Mito, Ibaragi 310
Tel: 0292-25-7470
Kyokawa Hewlett Packard Ltd
Inoue Building
1148-3, Asahimachi 1-chome
Atsugi, Kanagawa 243
Tel: 0462-24-0452
Kyokawa-Hewlett-Packard Ltd
Kunigaya Asahi
Nishiumi Building
4th Floor
3-4, Tsukuba
Kumagaya, Saitama 460
Tel: 0485-24-6841

Kyokawa Hewlett Packard Ltd

Nakano Building
24 Kam Satagami-cho
Naka-murakami, Nagoya 450
Tel: 052-571-5171
Kyokawa Hewlett Packard Ltd
Tengacha Building
2-24-1, Tsuyasaka-cho
Kanagawa-ku
Yokohama 221
Tel: 045-312-252
Telex: 382 3704 YHP YOK
Kyokawa Hewlett Packard Ltd
Mio Mitsui Building
105, 1-chome, San-nomaru
Mito, Ibaragi 310
Tel: 0292-25-7470
Kyokawa Hewlett Packard Ltd
Inoue Building
1148-3, Asahimachi 1-chome
Atsugi, Kanagawa 243
Tel: 0462-24-0452
Kyokawa-Hewlett-Packard Ltd
Kunigaya Asahi
Nishiumi Building
4th Floor
3-4, Tsukuba
Kumagaya, Saitama 460
Tel: 0485-24-6841

Kyokawa Hewlett Packard Ltd

Nakano Building
24 Kam Satagami-cho
Naka-murakami, Nagoya 450
Tel: 052-571-5171
Kyokawa Hewlett Packard Ltd
Tengacha Building
2-24-1, Tsuyasaka-cho
Kanagawa-ku
Yokohama 221
Tel: 045-312-252
Telex: 382 3704 YHP YOK
Kyokawa Hewlett Packard Ltd
Mio Mitsui Building
105, 1-chome, San-nomaru
Mito, Ibaragi 310
Tel: 0292-25-7470
Kyokawa Hewlett Packard Ltd
Inoue Building
1148-3, Asahimachi 1-chome
Atsugi, Kanagawa 243
Tel: 0462-24-0452
Kyokawa-Hewlett-Packard Ltd
Kunigaya Asahi
Nishiumi Building
4th Floor
3-4, Tsukuba
Kumagaya, Saitama 460
Tel: 0485-24-6841

Kyokawa Hewlett Packard Ltd

Nakano Building
24 Kam Satagami-cho
Naka-murakami, Nagoya 450
Tel: 052-571-5171
Kyokawa Hewlett Packard Ltd
Tengacha Building
2-24-1, Tsuyasaka-cho
Kanagawa-ku
Yokohama 221
Tel: 045-312-252
Telex: 382 3704 YHP YOK
Kyokawa Hewlett Packard Ltd
Mio Mitsui Building
105, 1-chome, San-nomaru
Mito, Ibaragi 310
Tel: 0292-25-7470
Kyokawa Hewlett Packard Ltd
Inoue Building
1148-3, Asahimachi 1-chome
Atsugi, Kanagawa 243
Tel: 0462-24-0452
Kyokawa-Hewlett-Packard Ltd
Kunigaya Asahi
Nishiumi Building
4th Floor
3-4, Tsukuba
Kumagaya, Saitama 460
Tel: 0485-24-6841

Kyokawa Hewlett Packard Ltd

Nakano Building
24 Kam Satagami-cho
Naka-murakami, Nagoya 450
Tel: 052-571-5171
Kyokawa Hewlett Packard Ltd
Tengacha Building
2-24-1, Tsuyasaka-cho
Kanagawa-ku
Yokohama 221
Tel: 045-312-252
Telex: 382 3704 YHP YOK
Kyokawa Hewlett Packard Ltd
Mio Mitsui Building
105, 1-chome, San-nomaru
Mito, Ibaragi 310
Tel: 0292-25-7470
Kyokawa Hewlett Packard Ltd
Inoue Building
1148-3, Asahimachi 1-chome
Atsugi, Kanagawa 243
Tel: 0462-24-0452
Kyokawa-Hewlett-Packard Ltd
Kunigaya Asahi
Nishiumi Building
4th Floor
3-4, Tsukuba
Kumagaya, Saitama 460
Tel: 0485-24-6841

Kyokawa Hewlett Packard Ltd

Nakano Building
24 Kam Satagami-cho
Naka-murakami, Nagoya 450
Tel: 052-571-5171
Kyokawa Hewlett Packard Ltd
Tengacha Building
2-24-1, Tsuyasaka-cho
Kanagawa-ku
Yokohama 221
Tel: 045-312-252
Telex: 382 3704 YHP YOK
Kyokawa Hewlett Packard Ltd
Mio Mitsui Building
105, 1-chome, San-nomaru
Mito, Ibaragi 310
Tel: 0292-25-7470
Kyokawa Hewlett Packard Ltd
Inoue Building
1148-3, Asahimachi 1-chome
Atsugi, Kanagawa 243
Tel: 0462-24-0452
Kyokawa-Hewlett-Packard Ltd
Kunigaya Asahi
Nishiumi Building
4th Floor
3-4, Tsukuba
Kumagaya, Saitama 460
Tel: 0485-24-6841

Kyokawa Hewlett Packard Ltd

Nakano Building
24 Kam Satagami-cho
Naka-murakami, Nagoya 450
Tel: 052-571-5171
Kyokawa Hewlett Packard Ltd
Tengacha Building
2-24-1, Tsuyasaka-cho
Kanagawa-ku
Yokohama 221
Tel: 045-312-252
Telex: 382 3704 YHP YOK
Kyokawa Hewlett Packard Ltd
Mio Mitsui Building
105, 1-chome, San-nomaru
Mito, Ibaragi 310
Tel: 0292-25-7470
Kyokawa Hewlett Packard Ltd
Inoue Building
1148-3, Asahimachi 1-chome
Atsugi, Kanagawa 243
Tel: 0462-24-0452
Kyokawa-Hewlett-Packard Ltd
Kunigaya Asahi
Nishiumi Building
4th Floor
3-4, Tsukuba
Kumagaya, Saitama 460
Tel: 0485-24-6841

Kyokawa Hewlett Packard Ltd

Nakano Building
24 Kam Satagami-cho
Naka-murakami, Nagoya 450
Tel: 052-571-5171
Kyokawa